

ETABS[®]

Integrated Building Design Software

Tutorial



**Computers and Structures, Inc.
Berkeley, California, USA**

Version 8
March 2003

Copyright

The computer program ETABS and all associated documentation are proprietary and copyrighted products. Worldwide rights of ownership rest with Computers and Structures, Inc. Unlicensed use of the program or reproduction of the documentation in any form, without prior written authorization from Computers and Structures, Inc., is explicitly prohibited.

Further information and copies of this documentation may be obtained from:

Computers and Structures, Inc.
1995 University Avenue
Berkeley, California 94704 USA

Phone: (510) 845-2177

FAX: (510) 845-4096

e-mail: info@csiberkeley.com (for general questions)

e-mail: support@csiberkeley.com (for technical support questions)

web: www.csiberkeley.com

© Copyright Computers and Structures, Inc., 1978-2000.

The CSI Logo is a registered trademark of Computers and Structures, Inc.

ETABS is a registered trademark of Computers and Structures, Inc.

Windows is a registered trademark of Microsoft Corporation.

Adobe and Acrobat are registered trademarks of Adobe Systems Incorporated.

DISCLAIMER

CONSIDERABLE TIME, EFFORT AND EXPENSE HAVE GONE INTO THE DEVELOPMENT AND DOCUMENTATION OF ETABS. THE PROGRAM HAS BEEN THOROUGHLY TESTED AND USED. IN USING THE PROGRAM, HOWEVER, THE USER ACCEPTS AND UNDERSTANDS THAT NO WARRANTY IS EXPRESSED OR IMPLIED BY THE DEVELOPERS OR THE DISTRIBUTORS ON THE ACCURACY OR THE RELIABILITY OF THE PROGRAM.

THE USER MUST EXPLICITLY UNDERSTAND THE ASSUMPTIONS OF THE PROGRAM AND MUST INDEPENDENTLY VERIFY THE RESULTS.

Tutorial

An Example Model

	The Project	2
Step 1	Begin a New Model	2
	Define an Auto Select Section List	5
Step 2	Add Line Objects	7
	Set Up to Add Objects to Multiple Stories Simultaneously	7
	Draw Column Objects	8
	Save the Model	13
	Draw the Lateral Force-Resisting Beam Objects	13
	Draw the Secondary (Infill) Beam Objects	15
Step 3	Add Area Objects	18
	Draw the Floor Area Objects	18
	Add Dummy Area Objects used for Wind Load Application	21
	Add Objects in Elevation View	21
	Add Objects in Plan View	22
Step 4	Define Static Load Cases	25

Step 5	Assign Gravity Loads	29
Step 6	Define a Developed Elevation	34
Step 7	Assign Wind Loads	37
Step 8	Review Database Display of Input Data	42
Step 9	Run the Analysis	44
Step 10	Graphically Review the Analysis Results	44
Step 11	Design the Composite Beams	47
Step 12	Design the Steel Frame	55

An Example Model

This manual provides step-by-step instructions for building a basic ETABS model. Each step of the model creation process is identified, and various model construction techniques are introduced. If you follow the instructions, you will build the model shown in Figure 1.

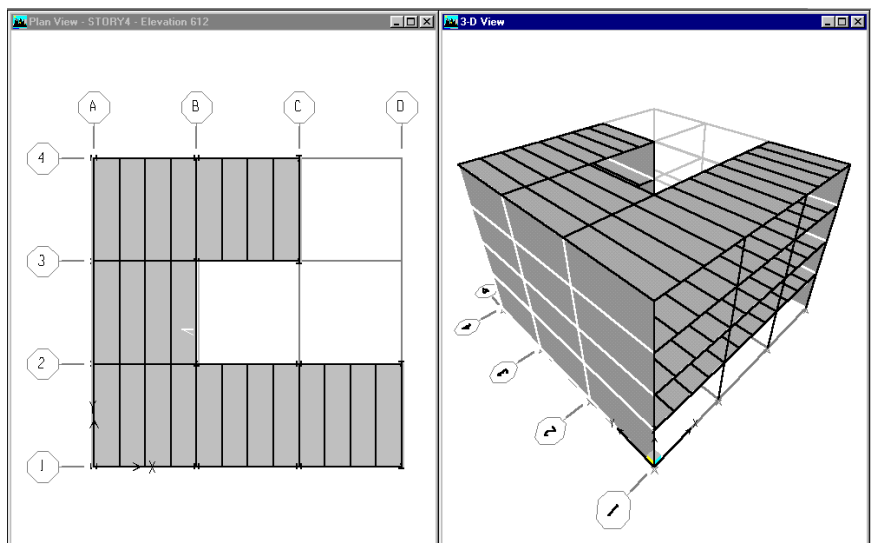

Figure 1
An Example
of a Model

The Project

The example project is an irregularly shaped four-story building. The first story is 15 feet high and stories 2, 3, and 4 are each 12 feet high. The bays are 24 feet in the X and Y directions.

The lateral force resisting system consists of intersecting moment frames. The floors consist of 3 inches of concrete over a 3-inch-deep metal deck. The secondary (infill) beams are designed as composite beams. The lateral-force resisting beams that connect the columns are designed as non-composite beams.

The architect for the building has requested that the maximum beam depth not exceed that of a W18 beam to allow sufficient clearance for ductwork running beneath the beams.

Step 1 Begin a New Model

In this Step, the dimensions and story height are set. Then a list of sections that fit the parameters set by the architect for the design are defined.

- A. Start the program and click the X on the Tip of the Day window to close it. If the units shown in the drop-down box in the lower right-hand corner of the ETABS window are not Kip-in, click the drop-down box to set the units to Kip-in.
- B. Click the **File menu** > **New Model** command or the **New Model** button . The form shown in Figure 2 will display.

Figure 2
The New
Model
Initialization
form

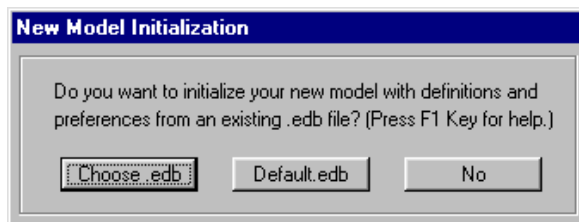

Figure 3
The Building Plan Grid System and Story Data Definition form

The screenshot shows a software dialog box titled "Building Plan Grid System and Story Data Definition". It is divided into several sections:

- Grid Dimensions (Plan):** Contains radio buttons for "Uniform Grid Spacing" (selected) and "Custom Grid Spacing". Below are four input fields: "Number Lines in X Direction" (4), "Number Lines in Y Direction" (4), "Spacing in X Direction" (288), and "Spacing in Y Direction" (288). There are "Grid Labels..." and "Edit Grid..." buttons.
- Story Dimensions:** Contains radio buttons for "Simple Story Data" (selected) and "Custom Story Data". Below are three input fields: "Number of Stories" (4), "Typical Story Height" (144), and "Bottom Story Height" (180). An "Edit Story Data..." button is next to the "Custom Story Data" option.
- Units:** A dropdown menu currently showing "Kip-in".
- Add Structural Objects:** A row of seven icons representing different structural models: "Steel Deck", "Staggered Truss", "Flat Slab", "Flat Slab with Perimeter Beams", "Waffle Slab", "Two Way or Ribbed Slab", and "Grid Only" (which is highlighted).

At the bottom of the dialog are "OK" and "Cancel" buttons.



Note:

*More information about templates is available by searching for "template" using the **Help menu > Search for Help on Help on command.***

- C. Select the **No** button on that form and the form shown in Figure 3 will display.

The Building Plan Grid System and Story Data form is used to specify horizontal grid line spacing, story data, and, in some cases, template models. Template models provide a quick, easy way of starting your model. They automatically add structural objects with appropriate properties to your model. We highly recommend that you start your models using templates whenever possible. However, in this example, the model is built from scratch, rather than using a template.

- D. Set the number of stories in the Number of Stories edit box to 4.
- E. Type **15 ft** into the Bottom Story Height edit box and press the Enter key on your keyboard (be sure you type *ft*). Notice that the program automatically converts the 15 ft to 180 because the current units are kips and inches (15 feet = 180 inches).
- F. Select the **Grid Only** button.

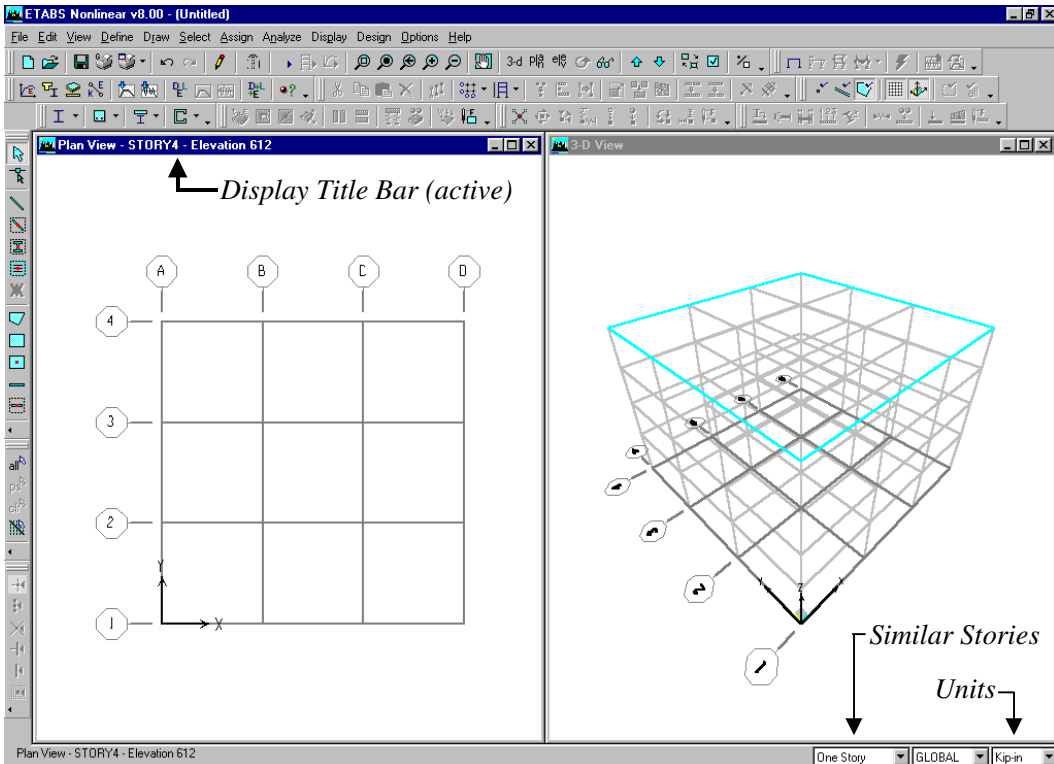

Figure 4

The ETABS main window

G. Click the **OK** button to accept your selections.

When you click the **OK** button, your model appears on screen in the main ETABS window with two view windows tiled vertically, a Plan View on the left and a 3-D View on the right, as shown in Figure 4. The number of view windows can be changed using the **Options menu > Windows** command.

Note that the Plan View is active in Figure 4. When the window is active, the display title bar is highlighted. Set a view active by clicking anywhere in the view window. If you change the views, return to the default described in the previous paragraph, with the Plan View active, before continuing with the next step in this manual.

Define an Auto Select Section List

An auto select selection list is simply a list of sections, for example, W18X35, W18X40, W21X44, W21X50 and W24X55. Auto select section lists can be assigned to frame members. When an auto select selection list is assigned to a frame member, the program can automatically select the most economical, adequate section from the auto select section list when it is designing the member.

The program has several built-in auto select section lists. Some of those lists will be used later in these instructions. Because the architect requested that the beams be no deeper than W18, it is useful to create an auto select section list that contains W16 and W18 beams now.

- A. Click the **Define menu > Frame Sections** command, which will display the Define Frame Properties form shown in Figure 5.

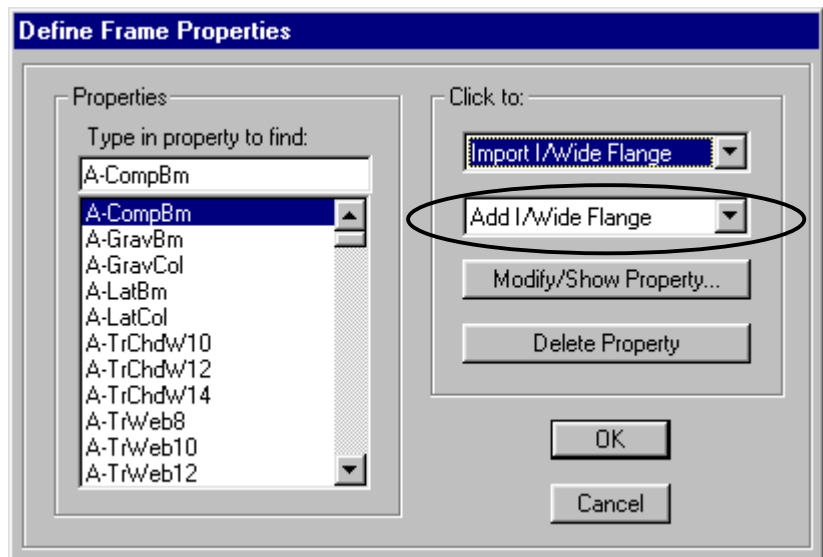

Figure 5
The Define Frame Properties form

- B. Click the drop-down box that reads "Add I/Wide Flange" in the Click To area of the Define Frame Properties form. Scroll down the resulting list of potential Add sections until you find *Add Auto Select List*. Double click on it. The Auto Selection Sections form shown in Figure 6 appears.
- C. Type **AUTOLATBM** in the Auto Section Name edit box.

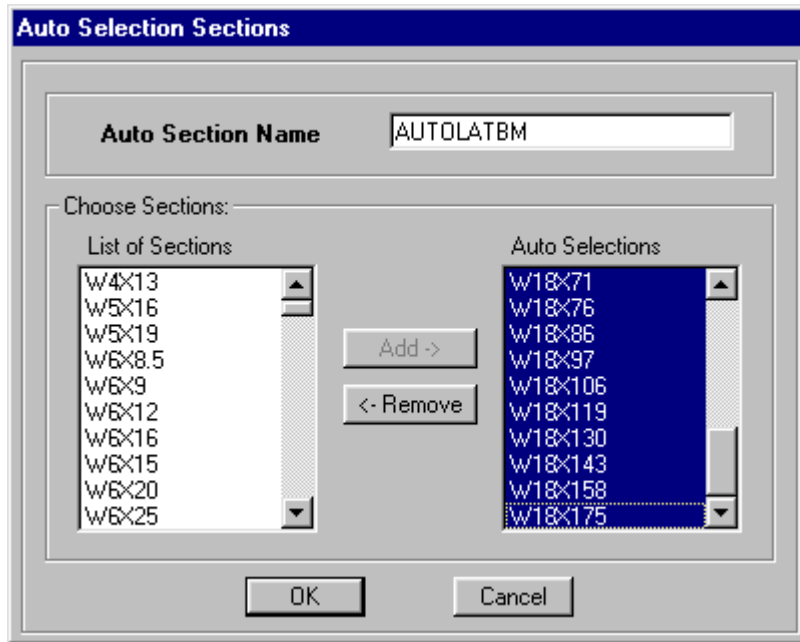

Figure 6
Auto Select
Sections
form

- D. Scroll down the list of beam sections in the List of Sections to find the W16X26 beam. Click once on that beam to highlight it.
- E. Scroll further down the list of beam sections in the List of Sections to find the W18X175 beam. Press the Shift key on your keyboard and then click once on the W18X175 beam. You should now have all of the beams between the W16X26 and the W18X175, inclusive, highlighted.
- F. Click the **Add** button to add the selected beams to the Auto Selections list on the right side of the form.
- G. Click the **OK** button and then click the **OK** button in the Define Frame Properties form to accept your changes.

Step 2 Add Line Objects

In this Step, the program is set up to add objects to multiple stories simultaneously. Then the structural objects are added to the model.

Set Up to Add Objects to Multiple Stories Simultaneously

Make sure that the Plan View is active. To make a window active, move the cursor, or mouse arrow, over the view and click the left mouse button. When a view is active, the Display Title Bar is highlighted. The location of the Display Title Bar is indicated in Figure 4.



Note:

The Similar Stories feature is only active when you are working in a Plan View.

- A. Click the drop-down box that reads "One Story" at the bottom right of the Main window, which is shown in Figure 4.
- B. Highlight **Similar Stories** in the list. This activates the Similar Stories option for drawing and selecting objects.
- C. To review the current Similar Story definitions, click the **Edit menu > Edit Story Data > Edit Story** command. The Story Data form shown in Figure 7 appears. Note the Master Story and Similar Story columns in the form.

With the Similar Stories option active, as additions or changes are made to a story—for example, Story 4—those additions and changes will also apply to all stories that have been designated as Similar To Story 4 on the Story Data form. By default, the program has defined Story 4 as a Master story and, as shown in Figure 7, Stories 1, 2 and 3 are Similar To Story 4. This means that, with Similar Stories active, any drawing or selection performed on any one story will apply to all of the other stories. A story can be set as Similar To NONE so that additions or changes will not affect it.

- D. We will not make any changes to the form, so press the **Cancel** button to close the form.

form, click in the Properties of Object box title bar, hold down the left mouse button, and drag the form out of the way.

- B. Make sure that the Property item on the Properties of Object form is set to A-LatCol. If it is not, click once in the edit box opposite the Property item to activate the drop-down box and then select A-LatCol from the resulting list. A-LatCol is a built-in auto select section list intended to be used for lateral force resisting columns.

If you want to review sections included in A-LatCol, or any of the other auto select section lists, (1) click the **Define menu > Frame Sections** command or click the **Define Frame Sections** button . The Define Frame Properties form will appear. (2) Highlight A-LatCol in the Properties drop down list. (3) Click the **Modify/Show Property** button. The Auto Selection Sections form appears; the sections included in the A-LatCol auto select section list are listed in the Auto Selections area of the form. (4) Click the **Cancel** button to close the form.

- C. Click in the Angle edit box on the Properties of Object form and set the angle to 90. This means that the columns will be rotated 90 degrees from their default position.
- D. To draw the first column, left click once in the Plan View at the intersection of grid lines D and 1. An I-shaped column should appear at that point in the Plan View. Also, in the 3D View, note that the column is displayed extending over all story levels even though the column was drawn at only one story level. This occurs because the Similar Stories feature is active. Note that the Similar Stories feature only applies when additions or changes are made to the model in the Plan View. The Similar Stories feature does not apply when additions or changes are made in the Elevation or 3D views.
- E. Click once in the Plan View at the intersection of grid lines D and 2 to draw the second column.
- F. Now change the angle item in the Properties of Object form from 90 to 0.

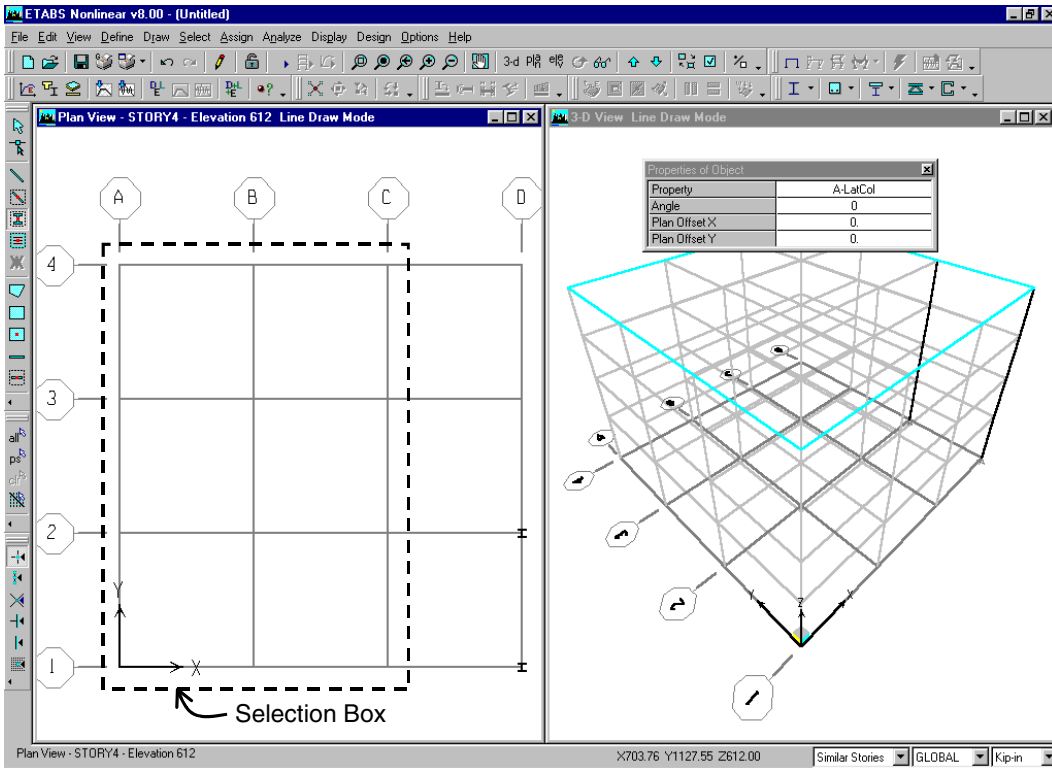



Figure 9
Drawing column objects in a windowed region

G. Now draw the remaining columns in one action by "windowing" around the grid intersections as shown in Figure 9. To "window," click the left mouse button above and to the left of grid intersection A-4 and then, while holding the left mouse button down, drag the mouse until it is below and to the right of grid intersection C-1. A selection box similar to that shown in Figure 9 should expand around the grid line intersections as the mouse is dragged across the model. Release the left mouse button and the program will draw the column objects at the grid line intersections.

Note that these columns appear rotated 90 degrees from the first two.

- H. Click the **Select Object** button, , to change the program from Draw mode to Select mode.
- I. Hold down the Ctrl key on your keyboard and left click once in the Plan View on column A-2. A selection list similar to the one shown

in Figure 10 pops up because multiple objects exist at the location that was clicked. In this example, a point object and a column object exist at the same location. Note that the selection list will only appear when the Ctrl key is used with the left click.

Figure 10
Selection List
form

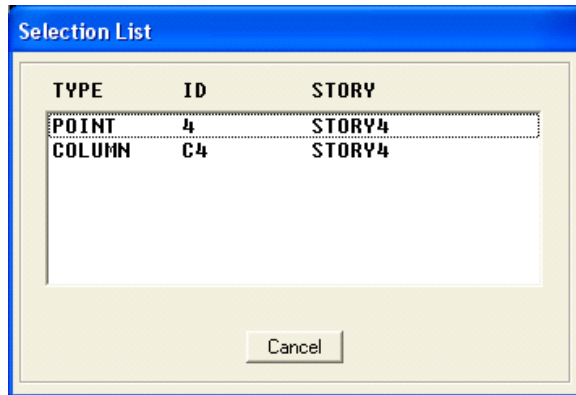

- J. Select the column from the list by clicking on it. The column at A-2 is now selected. It is selected over its entire height because the Similar Stories feature is active. Note that the status bar in the bottom right-hand corner of the main ETABS window indicates that 4 lines have been selected.
- K. Repeat the selection process at B-2, A-3, C-3 and C-4. The status bar should indicate that 20 lines have been selected.
- L. Click the **Assign menu > Frame/Line > Local Axes** command to bring up the form shown in Figure 11.

Figure 11
Axis Orientation
form for columns

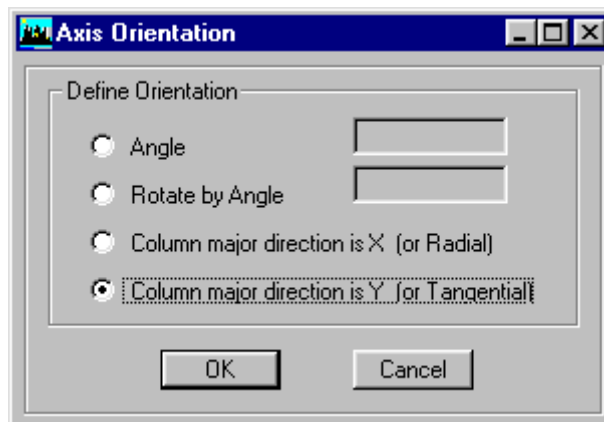



Note:

When the local axes are displayed, the color coded arrows are red, white and blue, corresponding to the 1, 2 and 3 axes respectively, always.

- M. Click the Column Major Direction is Y option in the form and then click the **OK** button. The selected columns rotate 90 degrees.

Notice the colored arrows associated with each column. Those arrows indicate the local axes directions. The red arrow is always in the local 1 direction, the white arrow is in the local 2 direction and the blue arrow is in the local 3 direction. Currently, the red arrow is not visible because it (and thus the column local 1-axis) is perpendicular to the screen.

An easy way to remember the color coding for the local axes is to think of the American flag. The American flag is red, white and blue. The color coding for the local axes is red = 1, white = 2 and blue = 3.

Figure 12

The example model with the columns drawn

Click the **Assign menu > Clear Display of Assigns** command to clear the display of the arrows.

The model should now appear as shown in Figure 12.

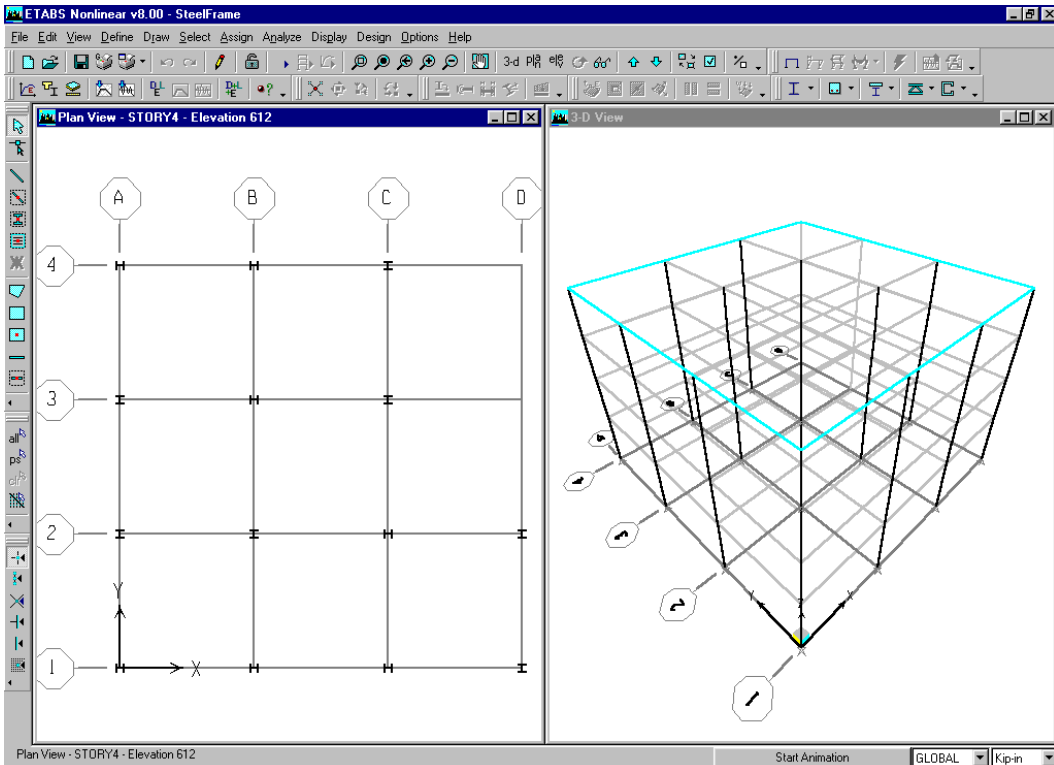



Note:

Save your model often!

Save the Model

During development, save the model often. Although typically you will save it with the same name, thus overwriting previous models, you may occasionally want to save your model with a different name. This allows you to keep a record of your model at various stages of development.

- A. Click the **File menu > Save** command, or the **Save** button, , to save your model. Specify the directory in which you want to save the model and, for this example, specify the file name SteelFrame.

Draw the Lateral Force-Resisting Beam Objects

Make sure that the Plan View is active. Draw the beams between the columns using the following Action Items.

- A. Click the **Create Lines in Region or at Clicks** button,  or the **Draw menu > Draw Line Objects > Create Lines in Region or at Clicks** command. The Properties of Object pop-up box for line objects shown in Figure 13 will appear.

Figure 13
Properties of
Object box



Properties of Object	
Type of Line	Frame
Property	A-LatBm
Moment Releases	Continuous
Plan Offset Normal	0.

- B. Click once in the edit box opposite the Property item to activate the drop-down box and then scroll down to select AUTOLATBM in the resulting list. Recall that AUTOLATBM is the auto select section list created in Step 1.
- C. Left click once in the Plan View on grid line D between grid lines 1 and 2. A beam is drawn along the selected grid line. Because the Similar Stories option is active, beams are created at all levels.
- D. In a similar manner, left click once on grid line 1 between grid lines C and D and then left click once on grid line 2 between grid lines C and D to draw beams in two more locations.

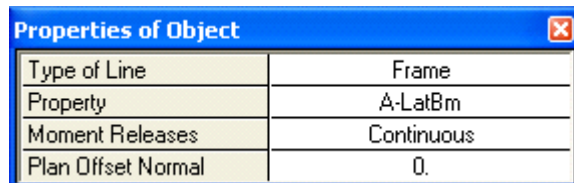
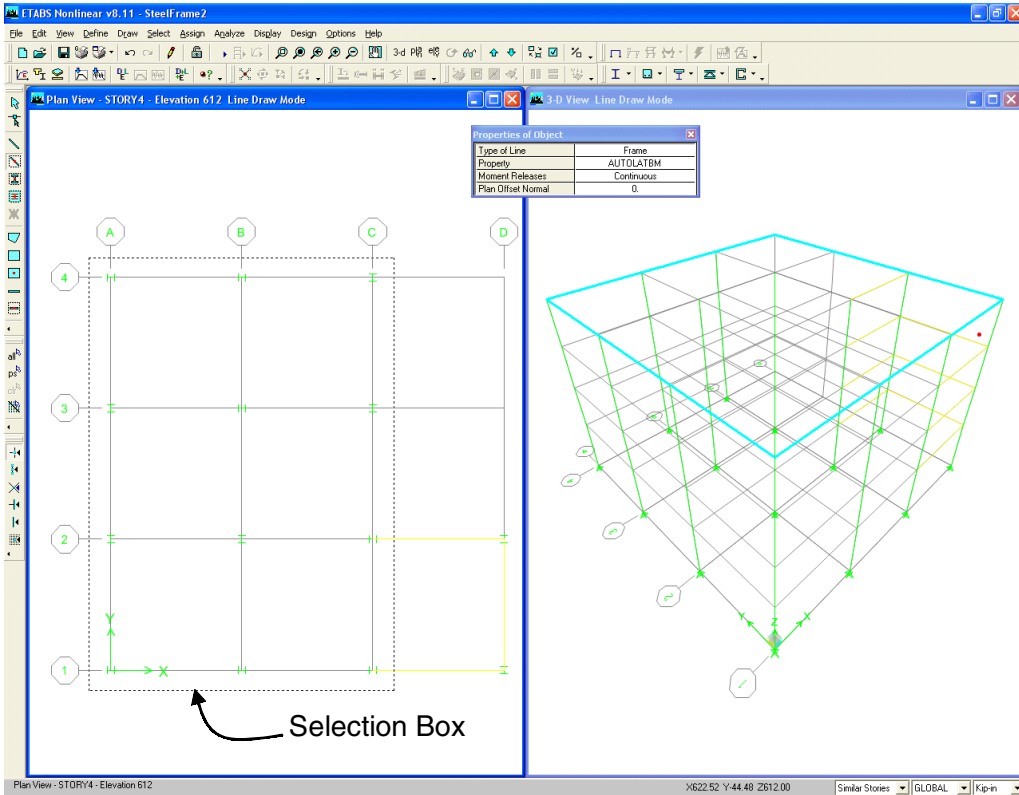





Figure 14
Drawing lateral force-resisting beam objects in a windowed region

- E. Now draw the remaining lateral force-resisting beams in one action by windowing around the grid lines to add beams between the columns drawn in Step 1, as shown in Figure 14. To window, click the left mouse button above and to the left of grid intersection A-4 and then, while holding the left mouse button down, drag the mouse until it is below and to the right of grid intersection C-1. A selection box will expand around the grid line intersections as the mouse is dragged across the model. Release the left mouse button to draw the beams.
- F. Click the **Select Object** button, , to change the program from Draw mode to Select mode.
- G. Left click once on the beam along grid line C between grid lines 2 and 3 to select it. Press the Delete key on your keyboard or click the **Edit menu > Delete** command to delete the selection because no beams should connect points C-3 and C-2 in the model.

- H. Click the **File menu > Save** command, or the Save button, , to save your model.

Draw the Secondary (Infill) Beam Objects

Make sure that the Plan View is active. Now draw the secondary beams that span between girders using the following Action Items.

- A. Click the **Create Secondary Beams in Region or at Clicks** button, , or the **Draw menu > Draw Lines Objects > Create Secondary Beams in Region or at Clicks** command. The Properties of Object pop-up box for beams shown in Figure 15 will appear.

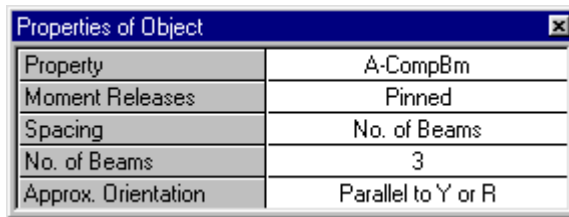

Figure 15
Properties of
Object box

Make sure that the Property item in this box is set to A-CompBm. If it is not, click once in the edit box opposite the Property item to activate the drop-down box and then select A-CompBm from the resulting list. A-CompBm is a built-in auto select section list intended to be used for composite secondary beams. Review the sections included in the A-CompBm auto select list as follows: (1) click the **Define menu > Frame Sections** command. (2) Highlight A-CompBm in the drop down list. (3) Click the **Modify/Show Property** button; the sections in the list are displayed in the Auto Selections area of the form. (4) When finished, click the **Cancel** buttons to close both forms.

Make sure that the Approx. Orientation item in the Properties of Object box is set to Parallel to Y or R.

- B. Left click once in the bay bounded by grid lines C, D, 1 and 2 to draw the first set of secondary beams.
- C. Draw the remaining secondary beams in one action by windowing around the bays where secondary beams are to be added, as shown in

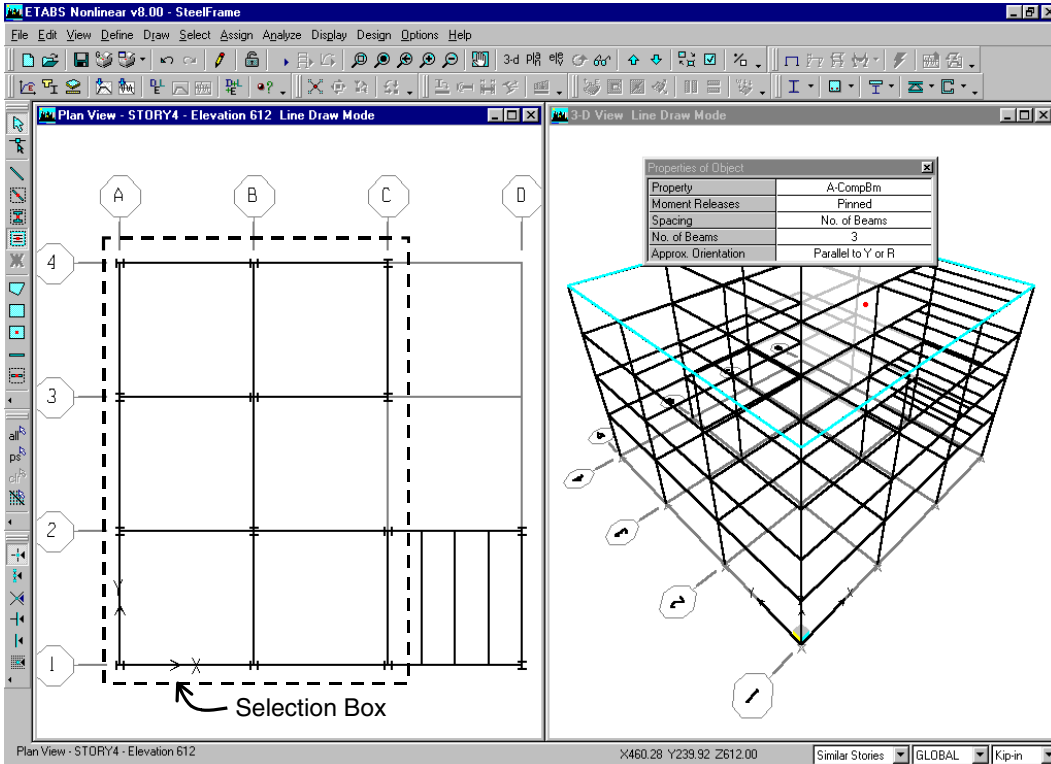



Figure 16
Drawing secondary beam objects in a windowed region

Figure 16. To window, click the left mouse button above and to the left of grid intersection A-4 and then, while holding the left mouse button down, drag the mouse until it is below and to the right of grid intersection C-1. A selection box similar to that shown in Figure 16 will expand as the mouse is dragged across the model. Release the left mouse button to draw the secondary beam objects.

- D. Click the **Select Object** button, , to change the program from Draw mode to Select mode.
- E. Click the **Select Using Intersecting Line** button, , or click the **Select menu > Using Intersecting Line** command to put the program in intersecting line select mode.

In intersecting line selection mode, left click the mouse once to start a line. Then, while holding the left mouse button down, drag the mouse to another location, thus creating a selection line. When the left mouse button is released, all objects that are crossed by the selection line are selected.

Refer to Figure 17. Left click the mouse in the Plan View between grid lines 2 and 3 just to the right of grid line B at the point labeled 1 in the figure. Holding down the left mouse button, drag the mouse pointer to the point labeled 2 in the figure. The selection line should be crossing the unwanted secondary beams in the bay bounded by grid lines 2, 3, B and C. Release the left mouse button to select the beams.

Figure 17
Selection
using an
intersecting
line

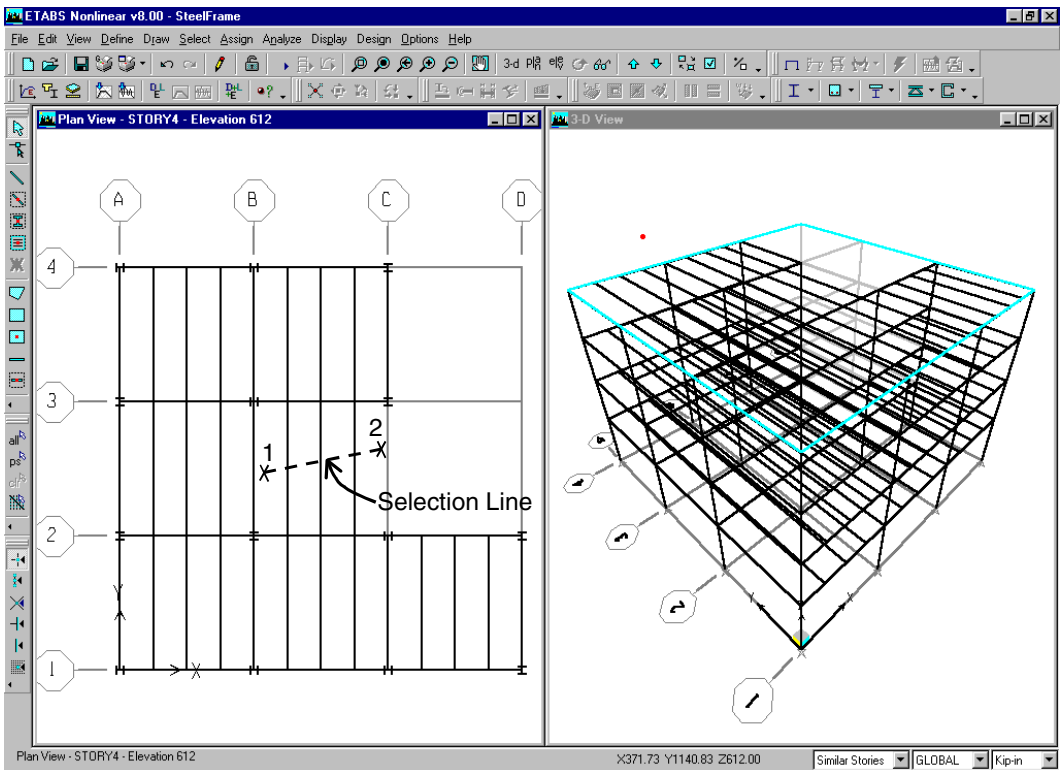

- F. Press the Delete key on your keyboard or click the **Edit menu > Delete** command to delete the selected beams from the model.
- G. Click the **File menu > Save** command, or the Save button, , to save your model.

Step 3 Add Area Objects

In this Step, floors are added to the model and a "dummy" area is created to which wind load can be assigned in Step 7.

Draw the Floor Area Objects

Make sure that the Plan View is active. Now draw an area object to represent the floor using the following Action Items.

- A. Click the **Draw Areas** button, , or select the **Draw menu > Draw Area Objects > Draw Areas** command. The Properties of Object pop-up box for areas shown in Figure 18 will appear.

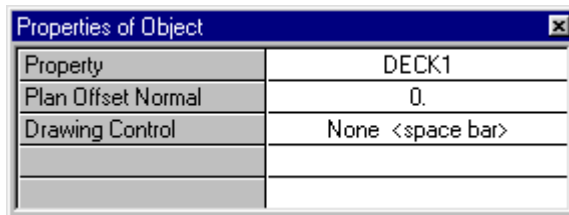



Figure 18
Properties of
Object box

Make sure that the Property item in this box is set to Deck1. If it is not, click once in the edit box opposite the Property item to activate the drop-down box and then select Deck1 in the resulting list. Deck1 is a built-in deck section property. The deck properties are reviewed in a subsequent Action Item of this step.

- B. Check that the **Snap to Grid Intersections and Points** command is active. This will assist in accurately drawing the area object. This command is active when its associated button  is depressed. Alternatively, use the **Draw menu > Snap To > Grid Intersections and Points** command to ensure that this command is active. By default, this command is active.

- C. Click once at column A-1. Then, moving clockwise around the model, click once at these intersection points in this order to draw the outline of the building: A-4, C-4, C-3, B-3, B-2, D-2, D-1 and back to A-1. Press the Enter key on your keyboard to complete the deck object.

If you have made a mistake while drawing this object, click the **Select Object** button, , to change the program from Draw mode to Select mode. Then click the **Edit menu > Undo Area Object Add** command. Repeat Action Items A through D.

Note in your model the two-headed arrow just above column B-2 that indicates the direction of the deck span. The deck is spanning in the global X-direction, perpendicular to the secondary beams. Note that the deck spans in the local 1-axis direction of the associated area object.



- D. Click the **Select Object** button, , to change the program from Draw mode to Select mode.
- E. To better view the deck addition, click the **Set Building View Options** button . When the Set Building View Options form appears, check the Object Fill check box and the Apply to All Windows check box, as shown in Figure 19.

Figure 19
Set Building
View Op-
tions form



Set Building View Options

View by Colors of:

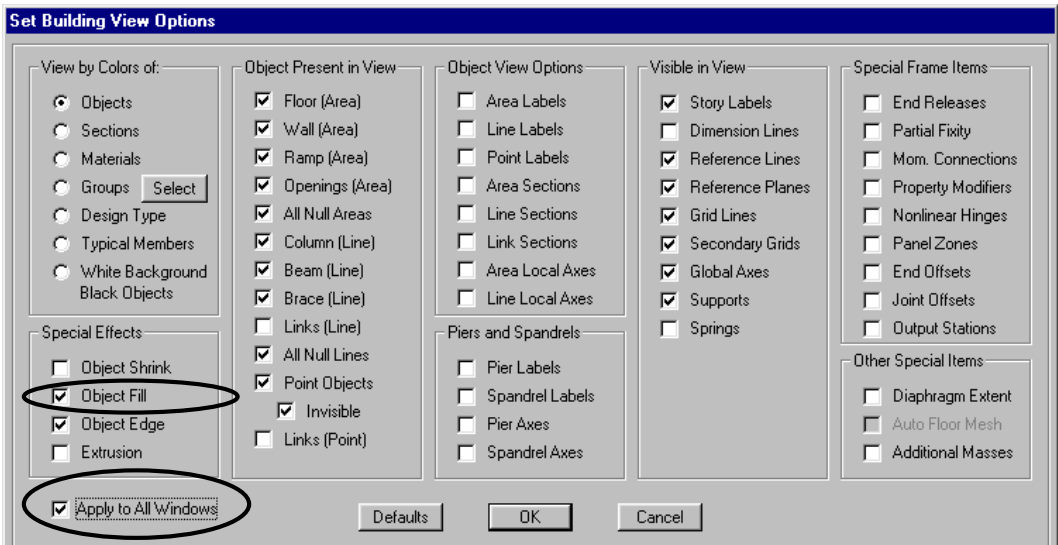
- Objects
- Sections
- Materials
- Groups
- Design Type
- Typical Members
- White Background Black Objects

Special Effects:

- Object Shrink
- Object Fill
- Object Edge
- Extrusion

Object Present in View:

- Floor (Area)
- Wall (Area)
- Ramp (Area)
- Openings (Area)
- All Null Areas
- Column (Line)
- Beam (Line)
- Brace (Line)
- Links (Line)
- All Null Lines
- Point Objects
- Invisible
- Links (Point)

Object View Options:

- Area Labels
- Line Labels
- Point Labels
- Area Sections
- Line Sections
- Link Sections
- Area Local Axes
- Line Local Axes

Piers and Spandrels:

- Pier Labels
- Spandrel Labels
- Pier Axes
- Spandrel Axes

Visible in View:

- Story Labels
- Dimension Lines
- Reference Lines
- Reference Planes
- Grid Lines
- Secondary Grids
- Global Axes
- Supports
- Springs

Special Frame Items:

- End Releases
- Partial Fixity
- Mom. Connections
- Property Modifiers
- Nonlinear Hinges
- Panel Zones
- End Offsets
- Joint Offsets
- Output Stations

Other Special Items:

- Diaphragm Extent
- Auto Floor Mesh
- Additional Masses

Apply to All Windows

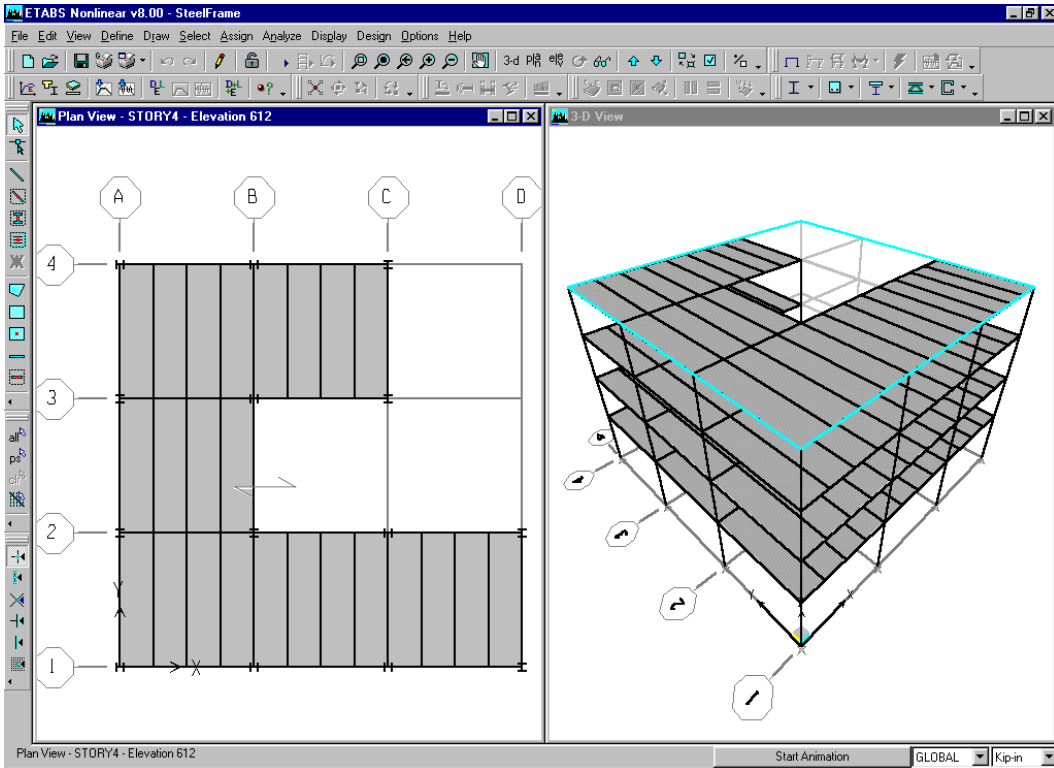

Figure 20
Model after the floor area objects have been added

The model now appears as shown in Figure 20.



- F. Review the Deck1 property that was assigned to the deck section. Click the **Define menu > Wall/Slab/Deck Sections** command to bring up the Define Wall/Slab/Deck Sections form.
 1. Highlight the Deck1 section and click the **Modify/Show Section** button. The Deck Section form shown in Figure 21 appears.
 2. Set the Slab Depth (tc) item to 3 to indicate that the slab depth above the metal deck is 3 inches.
 3. Click the **OK** button and then click the **OK** button in the Define Wall/Slab/Deck Sections form to accept your changes.
- G. Click the **File menu > Save** command, or the Save button, , to save your model.

Figure 21
Deck
Section
form

Add Dummy Area Objects used for Wind Load Application

Some "dummy" area objects that have no mass or stiffness will be added to the model. The areas will be used in Step 7 to apply wind load to the building.

Add Objects in Elevation View

- A. Set the 3D View active by clicking in it. The view is active when its title bar is highlighted.
- B. Click the **Elevation View** button  and select A (i.e., grid line A) from the Set Elevation View form; click the **OK** button. The 3D View changes to an Elevation View of grid line A.

- C. Click the **Create Areas at Click** button, , or click the **Draw menu > Draw Area Objects > Create Areas at Click** command. A Properties of Object box for area objects will appear. Click the Property edit box and select NONE from the resulting drop-down box.

Figure 22
Model in Elevation View after dummy area objects have been added along line A

- D. Click once in each of the bays shown in this elevation view to add the dummy area elements. Figure 22 shows the model with the dummy wall-type objects that have no mass or stiffness added along line A.

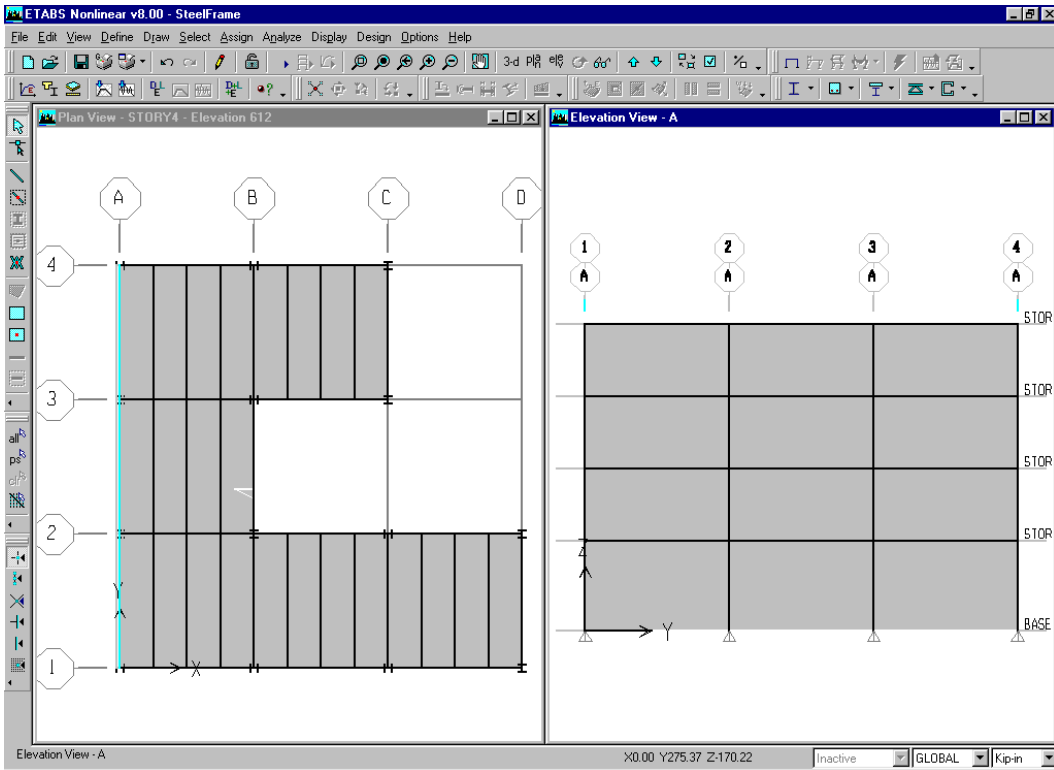

Add Objects in Plan View

- A. Make sure the Elevation View is active. The view is active when its title bar is highlighted.



- B. Click the Plan View button  and select Story 4 from the Select Plan Level form.
- C. Click the **Create Walls in Region or at Click** button, , or click the **Draw menu > Draw Area Objects > Create Walls in Region or at Clicks** command. A Properties of Object box will appear for area objects. Click the Property edit box and select NONE from the resulting drop-down box.
- D. Click once on grid line C between grid lines 3 and 4; click once on grid line B between grid lines 2 and 3; and click once on grid line D between grid lines 1 and 2, as shown in Figure 23. Dummy-type walls with no stiffness or mass are added to the model at all levels because the Similar Stories feature is active and the command was executed in Plan View.

Figure 23
Adding dummy wall-type objects in Plan View



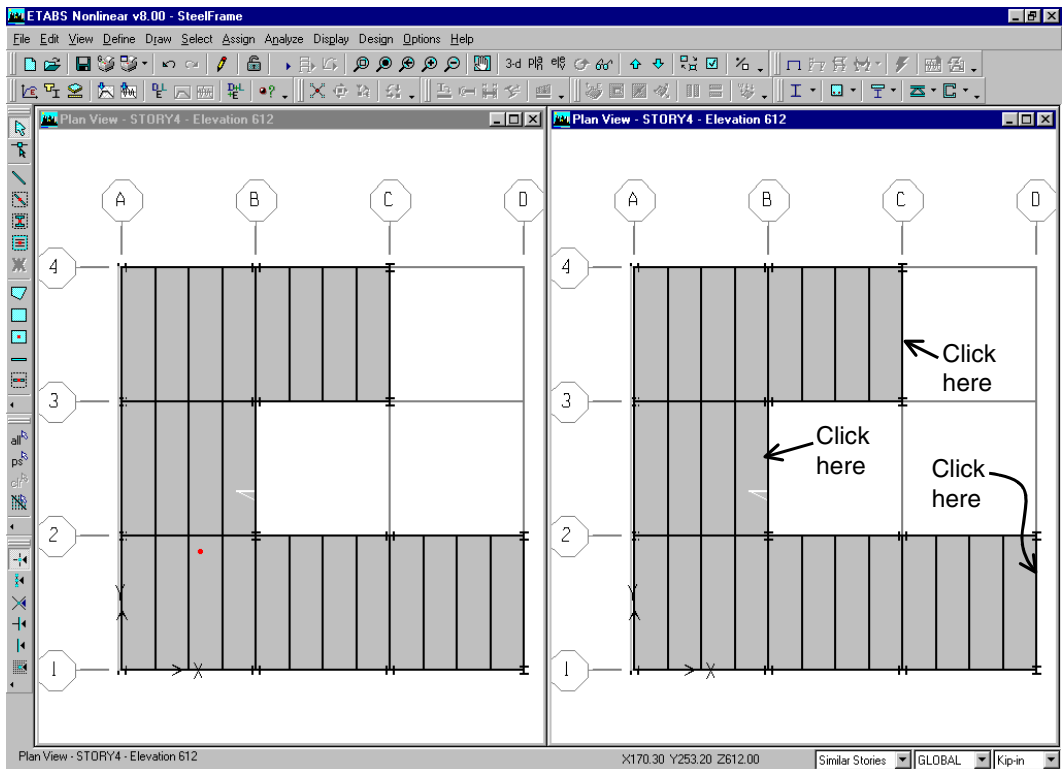

- E. Click the **Select Object** button, , to change the program from Draw mode to Select mode.
- F. Make sure the right-hand Plan View is active. Click on the Set Default 3D View button, , to change the Plan View to a 3D View.
- G. Click the **File menu** > **Save** command, or the Save button, , to save your model.

Figure 24
Model after all dummy wall-type objects have been added

Your model now appears as shown in Figure 24.

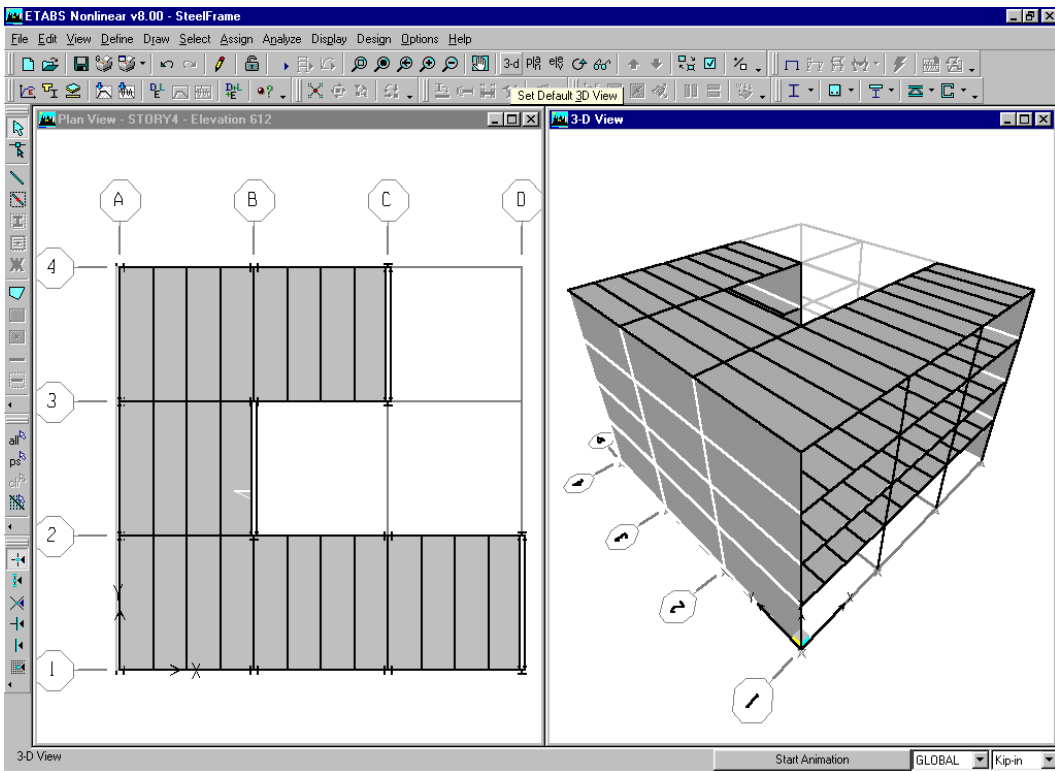

Step 4 Define Static Load Cases

The static loads used in this example consist of the dead, live, earthquake and wind loads acting on the building.

For this example building assume that the dead load consists of the self weight of the building structure, plus 35 psf (pounds per square foot) additional dead load applied to the floors and 250 plf (pounds per linear foot) additional dead load applied to the beams around the perimeter of the building. The 35 psf additional dead load applied to the floors accounts for items such as partitions, ceiling, mechanical ductwork, electrical items, plumbing, and so forth. The 250 plf additional dead load around the perimeter accounts for the cladding.

The live load is taken to be 100 psf at each story level. This live load is reducible for steel frame and composite beam design.



Note:

An unlimited number of static load cases can be defined in ETABS.

Note that realistically those loads would probably vary at some of the different floor levels. However, for the purposes of this example, we have chosen to apply the same load to each story level.

This example also applies a UBC97 static earthquake load to the building and an ASCE 7-98 wind load to the building. The forces that are applied to the building to account for the earthquake and wind load are automatically calculated by the program.

- A. Click the **Define menu > Static Load Cases** command or click the **Define Static Load Cases** button, , to bring up the Define Static Load Cases form shown in Figure 25. Note that there are two default load cases defined. They are DEAD, which is a dead load case, and LIVE, which is a live load case.

Note that the self weight multiplier is set to 1 for the DEAD case. This indicates that this load case will automatically include 1.0 times the self weight of all members.

- B. Click on LIVE to highlight the row as shown in Figure 25. Select REDUCE LIVE from the Type drop-down menu. Click the **Modify**

Figure 25
Define Static
Load Case
Names form

Load	Type	Self Weight Multiplier	Auto Lateral Load
LIVE	LIVE	0	
DEAD	DEAD	1	
LIVE	LIVE	0	

Click To:

Add New Load

Modify Load

Modify Lateral Load

Delete Load

OK

Cancel

Load button to change the load type from live to reducible live. We will apply live load to the structure later.

- C. Click in the edit box for the Load column. Type the name of the new load; in this case, type **SDEAD**. Select a Type of load from the Type pull down menu; in this case, select SUPERDEAD. Make sure that the Self Weight Multiplier is set to zero. Self weight should be included in only one load case; otherwise, self weight might be double counted in the analysis. In this example, self weight has been assigned to the DEAD load case. Click the **Add New Load** button to add the SDEAD load to the Load list.
- D. Repeat Action Item C to add a SUPERDEAD-type load named CLADDING. We will apply superimposed dead load to the structure later.
- E. To define the UBC97 earthquake load, click in the edit box for the Load column again and type EQY. Select QUAKE for the Load Type. Make sure the Self Weight Multiplier is zero. Use the Auto Lateral Load pull-down menu to select UBC97; with this option selected, ETABS will automatically apply static earthquake load based on the 1997 UBC code requirements. Click the **Add New Load** button.
- F. With the EQY load highlighted, click the **Modify Lateral Load** button. This will bring up the 1997 UBC Seismic Loading form (the UBC97 form comes up because the Auto Lateral Load type was set

Figure 26
1997 UBC
Seismic
Loading
form

The image shows a software dialog box titled "1997 UBC Seismic Loading". It is divided into several sections:

- Direction and Eccentricity:** Contains radio buttons for "X Dir", "Y Dir" (which is selected and circled), "X Dir + Eccen Y", "Y Dir + Eccen X", "X Dir - Eccen Y", and "Y Dir - Eccen X". Below these are input fields for "% Eccen (all Diaphragms)" and an "Override Eccentricities" button.
- Seismic Coefficients:** Contains radio buttons for "Per Code" (selected) and "User Defined". Below are dropdown menus for "Soil Profile Type" (set to "SC") and "Seismic Zone Factor" (set to "0.40"), and input fields for "User Defined: Ca" (set to "0.4") and "User Defined: Cv" (set to "0.56").
- Time Period:** Contains radio buttons for "Method A", "Program Calc" (selected), and "User Defined". Below are input fields for "Cl (R) = " (set to "0.035") and "T = ".
- Near Source Factor:** Contains radio buttons for "Per Code" (selected) and "User Defined". Below are dropdown menus for "Seismic Source Type" (set to "B") and "Dist. to Source (km)" (set to "15"), and input fields for "User Defined: Ns" and "User Defined: Nv".
- Story Range:** Contains dropdown menus for "Top Story" (set to "STORY4") and "Bottom Story" (set to "BASE").
- Factors:** Contains an input field for "Overstrength Factor, R" (set to "8.5").
- Other Factors:** Contains an input field for "Importance Factor, I" (set to "1").

At the bottom of the dialog are "OK" and "Cancel" buttons.

to UBC97 in item E). On this form, click the Y Dir option at the top of the form, as shown in Figure 26. Click the **OK** button. The Define Static Load Case Names form reappears.

- G. To define the ASCE7-98 wind load, click in the edit box for the Load column again and type WINDX. Select WIND as the Type. Select ASCE7-98 from the Lateral Load pull down menu. Click the **Add New Load** button.
- H. With the WINDX load highlighted, click the **Modify Lateral Load** button. This will bring up the ASCE 7-98 Wind Loading form shown in Figure 27 (the ASCE 7-98 form comes up because the Auto Lateral Load type was set to ASCE 7-98 in item G). Select the Exposure from Area Objects option. Notice that the form changes.

The Exposure from Area Objects option means that the wind load is being defined from user-specified wind pressure coefficients applied to the dummy vertical elements that were drawn earlier in Step 3.

Figure 27
ASCE 7-98
Wind Loading
form

Type 100 into the edit box for Wind Speed, as shown in Figure 27 and then click the **OK** button. The Define Static Load Case Names form reappears.

The Define Static Load Case Names form should now appear as shown in Figure 28. Click the **OK** button in that form to accept all of the newly defined static load cases.

Figure 28
The Define
Static Load
Case
Names form
after all
static load
cases have
been
defined.

Load	Type	Self Weight Multiplier	Auto Lateral Load
WINDX	WIND	0	ASCE 7-98
DEAD	DEAD	1	
LIVE	REDUCE LIVE	0	
SDEAD	SUPER DEAD	0	
CLADDING	SUPER DEAD	0	
EQY	QUAKE	0	UBC 97
WINDX	WIND	0	ASCE 7-98

- I. Click the **File menu > Save** command, or the **Save** button, , to save your model.

Step 5 Assign Gravity Loads

In this Step, the superimposed dead and live gravity loads will be applied to the model. Make sure that the Similar Stories feature is enabled and that the Plan View is active.

- A. Click anywhere on the deck (but not on a beam) to select the deck. A dashed line should appear around the perimeter of the deck. This dashed line indicates that the deck has been selected. If you make a mistake in selecting, press the **Clear Selection** button, , and try again.

The status bar in the lower left-hand corner of the Main ETABS window should indicate that four area objects have been selected because the Similar Stories feature is active.

- B. Click the **Assign > Shell/Area Loads > Uniform** command or click the **Assign Uniform Load** button, . This brings up the Uniform Surface Loads form. Select SDEAD from the Load Case Name drop-down box, as shown in Figure 29.

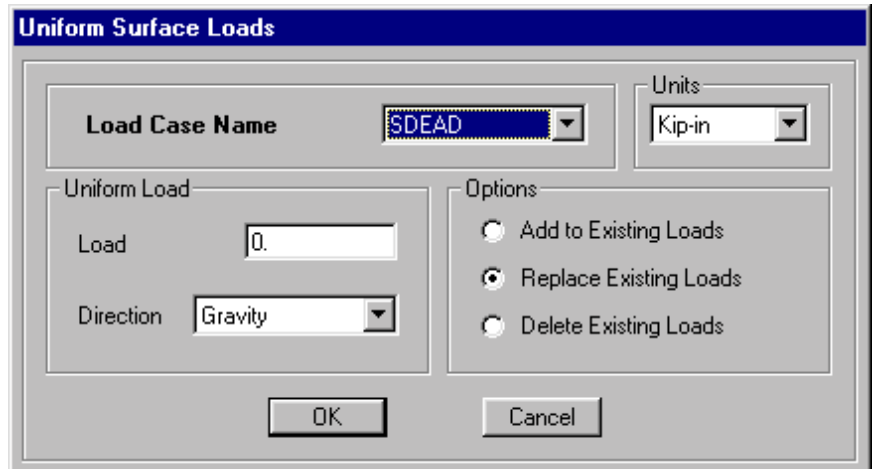

The screenshot shows the 'Uniform Surface Loads' dialog box. The 'Load Case Name' dropdown is set to 'SDEAD'. The 'Units' dropdown is set to 'Kip-in'. In the 'Uniform Load' section, the 'Load' field contains '0.' and the 'Direction' dropdown is set to 'Gravity'. In the 'Options' section, the 'Replace Existing Loads' radio button is selected. The 'OK' and 'Cancel' buttons are at the bottom.

Figure 29
The Uniform
Surface
Loads form

Note that the Direction specified for the load is Gravity. The gravity load direction is downward; that is, in the negative Global Z direction.

1. Hold down the Shift key and double click in the Load field to display the Calculator form, shown in Figure 30. This built-in calculator has a number of functions that are useful for assigning loads. In this case, it will be used to convert units and assign the superimposed dead load in lb-ft.

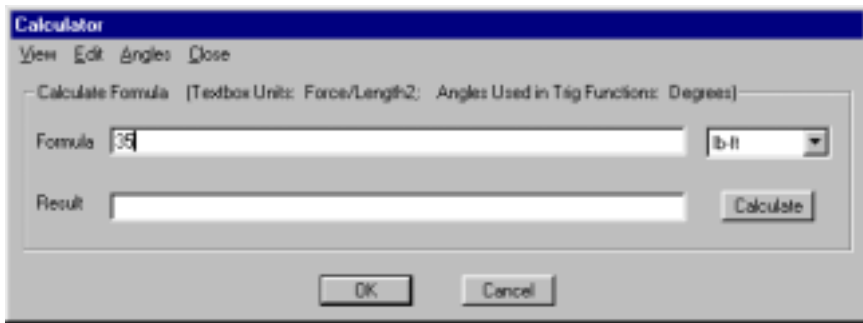



Figure 30
The Calculator form

Note that the calculator displays that the Load text box has units of Force over Length squared (Force/Length²).

Select lb-ft from the drop down list in the Calculator form and then type **35** in the Formula edit box. Be sure to set the units ***before*** typing 35.

Click the **OK** button on the Calculator form; ETABS automatically converts the lb-ft input into Kip-inch, displaying the result, 2.43055555555556E-04 kips/in², on the Uniform Surface Load form.

2. Click the **OK** button on the Uniform Surface Load form to accept the superimposed dead load.
- C. Click anywhere on the deck (but not on a beam) to select the deck.
- D. Click the **Assign > Shell/Area Loads > Uniform** command or click the **Assign Uniform Load** button, . This brings up the Uniform

Surface Loads form. Select LIVE from the Load Case Name drop-down box.

1. Set the units drop-down box in the form to lb-ft and then enter 100 in the Load edit box. The Uniform Surface Loads form should now appear as shown in Figure 31.

The screenshot shows a dialog box titled "Uniform Surface Loads". It contains the following fields and options:

- Load Case Name:** LIVE (dropdown menu)
- Units:** lb-ft (dropdown menu)
- Uniform Load:**
 - Load:** 100 (text input box)
 - Direction:** Gravity (dropdown menu)
- Options:**
 - Add to Existing Loads
 - Replace Existing Loads
 - Delete Existing Loads

At the bottom of the dialog are "OK" and "Cancel" buttons.

Figure 31
The Uniform Surface Loads form

2. Click the **OK** button on the Uniform Surface Load form to accept the live load.

- E. Check that the **Snap to Grid Intersections and Points** command is **not** active. This will make it easier to select the perimeter beams. This command is active when its associated button  is depressed. Thus, make sure the button is **not** depressed. You can also toggle the snap feature using the **Draw menu > Snap To > Grid Intersections and Points** command.



Note:

We strongly recommend that you apply perimeter cladding loads to the spandrel beams objects, not to the deck objects.

- F. Select the perimeter beam along grid line A between grid lines 1 and 2 by left clicking on it once in Plan View. Notice that the status bar in the lower left-hand corner of the main ETABS window indicates that four lines have been selected because the Similar Stories feature is active. Also note that the selected lines appear dashed.
- G. Select the other thirteen perimeter beams in a similar manner. When you have selected all perimeter beams, the status bar should indicate

that 56 lines have been selected (14 beams times 4 stories = 56 beams).

- H. Click the **Assign > Frame/Line Loads > Distributed** command or click the **Assign Frame Distributed Load** button, . This brings up the Frame Distributed Loads form shown in Figure 32. Select **CLADDING** from the Load Case Name drop-down box.

Figure 32
The Frame Distributed Loads form



The screenshot shows the 'Frame Distributed Loads' dialog box. At the top, the title bar reads 'Frame Distributed Loads'. Below it, there are several sections:

- Load Case Name:** A drop-down menu showing 'CLADDING'.
- Units:** A drop-down menu showing 'lb-ft'.
- Load Type and Direction:** Two radio buttons, 'Forces' (selected) and 'Moments'. Below them is a 'Direction' drop-down menu showing 'Gravity'.
- Options:** Three radio buttons: 'Add to Existing Loads', 'Replace Existing Loads' (selected), and 'Delete Existing Loads'.
- Trapezoidal Loads:** A table with four columns labeled 1, 2, 3, and 4. Each column has a 'Distance' and a 'Load' input field. All 'Distance' and 'Load' fields contain the value '0'.
- Relative Distance from End-I:** Two radio buttons: 'Relative Distance from End-I' (selected) and 'Absolute Distance from End-I'.
- Uniform Load:** A section with a 'Load' input field containing the value '250'. This field is circled in red.
- Buttons:** 'OK' and 'Cancel' buttons are located at the bottom right.

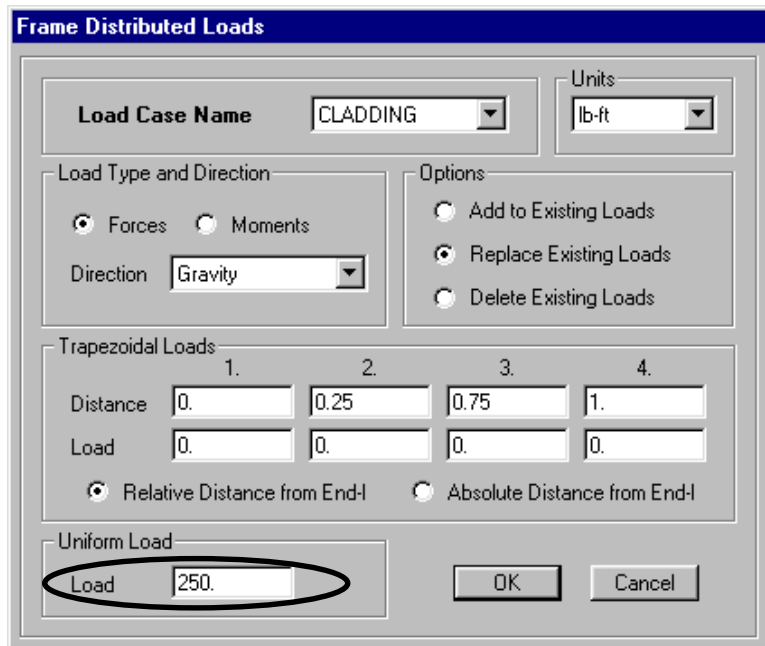
1. Set the units drop-down box in the form to lb-ft and then enter 250 in the Load edit box that is located in the Uniform Load area of the form.
2. Click the **OK** button on the Frame Distributed Loads form to accept the uniform superimposed dead load that is applied to the perimeter beams to represent the cladding.

Note that the Frame Distributed Loads form also has a Delete Existing Loads check box. To delete a load assignment, select the beam(s) and use the **Assign > Frame/Line Loads > Distributed** command or the **Assign Frame Distributed Load** button,  to access this form. In the Load Case Name drop-down box, locate the load to be re-

moved, check the Delete Existing Loads check box and click the **OK** button.

- I. Make sure the Plan View is active. Click on the Set Default 3D View button, , to change the Plan View to a 3D View. You should now be able to graphically see the load applied to the perimeter beams, as illustrated in Figure 33.

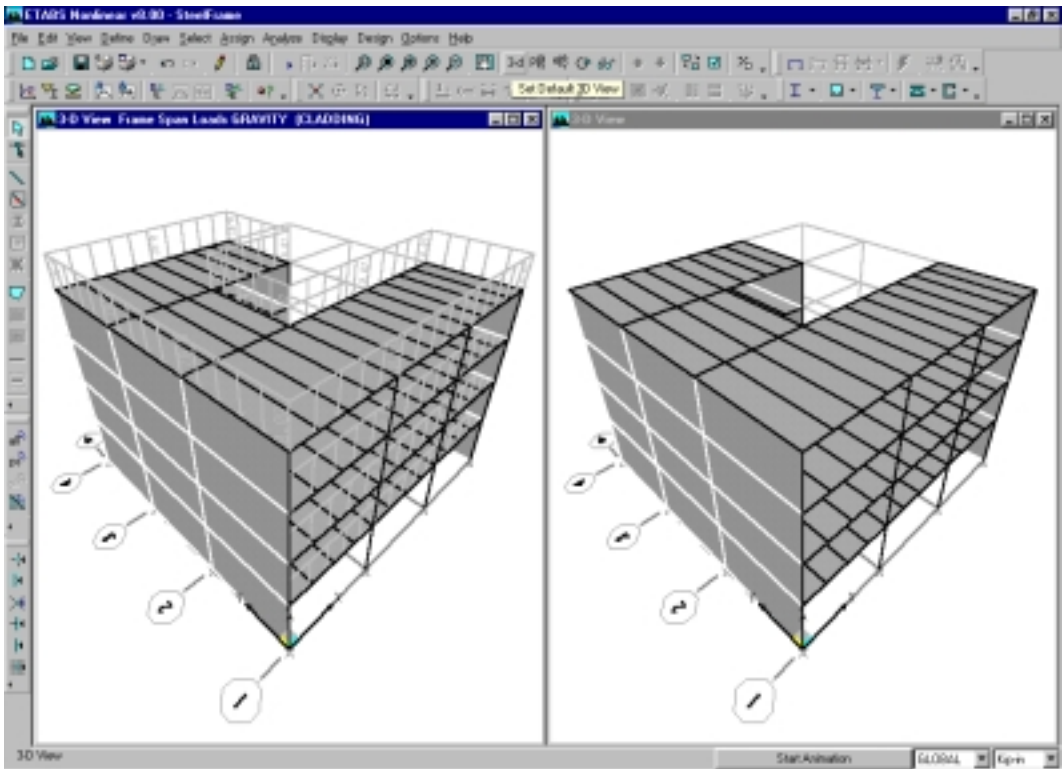



Figure 33
Frame distributed loads applied to the perimeter beams

- J. Click the **Assign menu > Clear Display of Assigns** command to clear the display of the assigned loads.
- K. Make sure the left-hand 3D view is active. Click the Plan View button  and select Story 4 from the Select Plan Level form.
- L. Click the **File menu > Save** command, or the **Save** button, , to save your model.

Step 6 Define a Developed Elevation

In this Step, a Developed Elevation View of the right-hand side of the building will be defined so that the wind load can be assigned to it in Step 7.

- A. Click the **Draw menu > Draw Developed Elevation Definition** command to bring up the Elevations Views form shown in Figure 34.

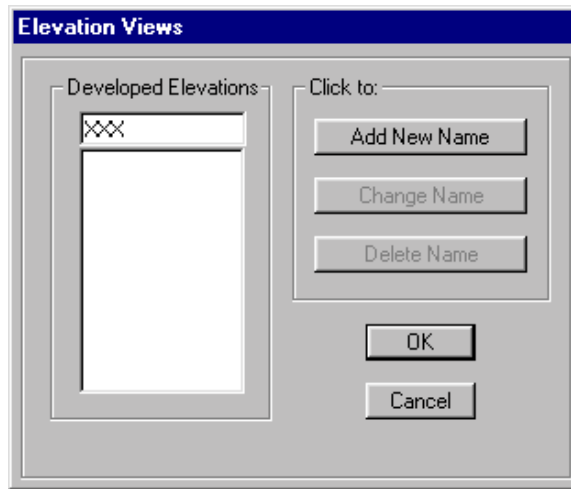



Figure 34
The Elevation Views form

1. Type **XXX** in the Developed Elevations edit box, as shown in the figure. This will be the name of the Developed Elevation.
 2. Click the **Add New Name** button and then click the **OK** button. Note that both views are now Plan Views and that the Developed Elevation draw mode is active. The model appears as shown in Figure 35.
- B. Check that the **Snap to Grid Intersections and Points** command is active. This will assist in accurately drawing the developed elevation definition. This command is active when its associated button  is depressed. Alternatively, use the **Draw menu > Snap To > Grid Intersections and Points** command to ensure that this command is active. By default, this command is active.

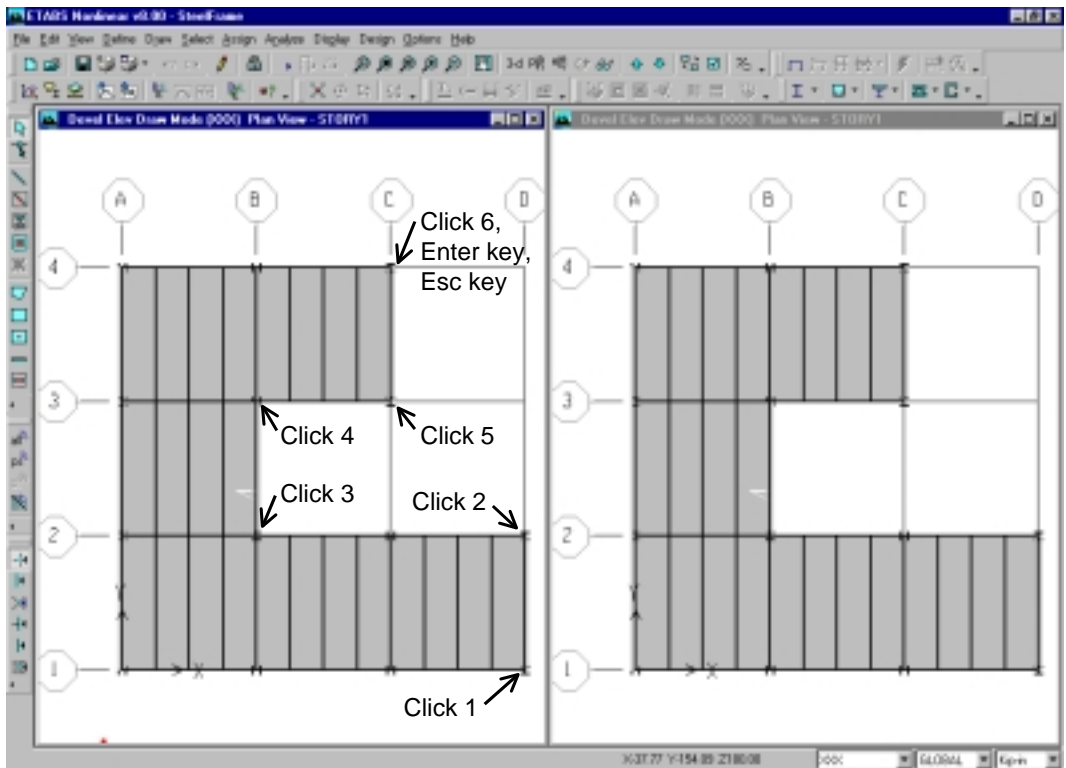



Figure 35
Developed
elevation
draw mode

- C. Working in the left-hand Plan View (note that this can be completed in either Plan View), left click once at Grid D-1. Then moving counterclockwise around the building, left click once at D-2, B-2, B-3, C-3 and C-4 in that order. The sequence of clicks is illustrated in Figure 35.
- D. When all of the points have been clicked, press the Enter key on your keyboard to finish drawing the developed elevation definition.
- E. Press the Esc key on your keyboard to exit the Developed Elevation draw mode. Notice that the views return to those that existed before enabling the Developed Elevation draw mode.
- F. Make sure the Plan View is active. Click the **Elevation View** button  and select XXX (the developed elevation just defined) from the Set Elevation View form; click the **OK** button. The Plan View changes to a Developed Elevation View, as illustrated in Figure 36.

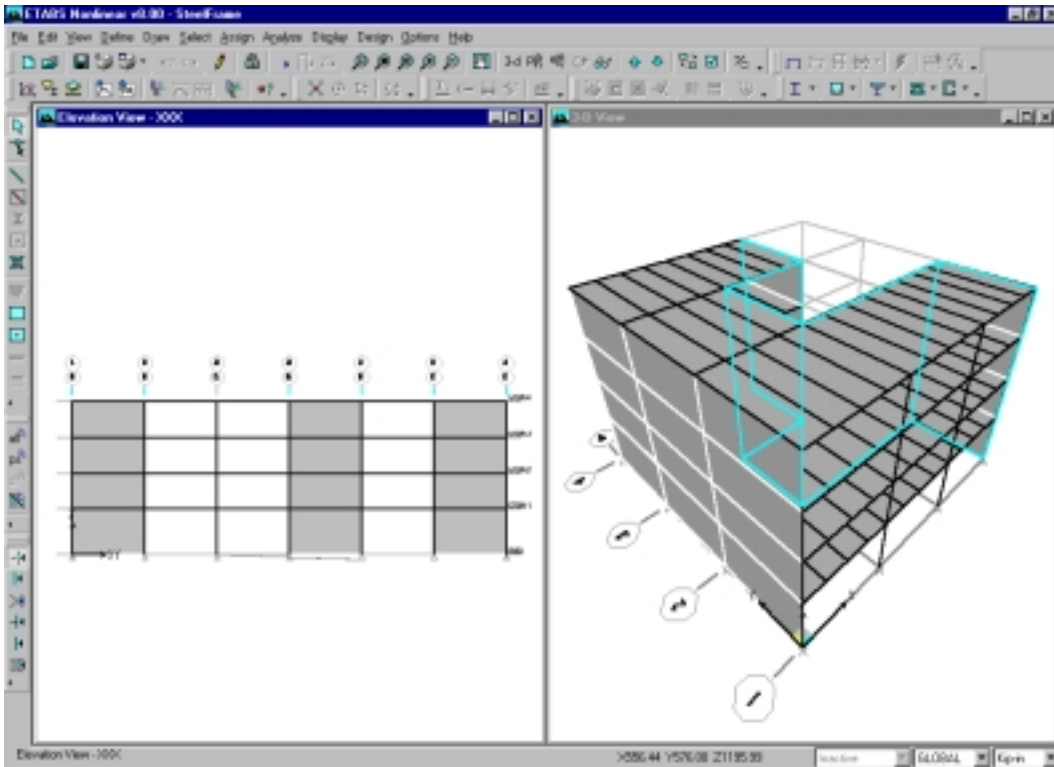



Figure 36
Developed
Elevation
View

The developed elevation is an "unfolded" view of the newly defined elevation. The scope of the developed elevation is illustrated by the cyan-colored lines in the 3D View.

As many developed elevations as desired can be defined. Note however, that a developed elevation can not cross itself and it can not close on itself. Either of those situations would require that the same point occur in two different locations within the developed elevations, which is not allowed.

After a developed elevation has been defined, it can be viewed, objects can be drawn on it, assignments can be made to objects in it, and so forth, similar to any other Elevation View. The XXX Elevation View will be used in the next step.

- G. Make sure the Developed Elevation View (i.e., Elevation View XXX) is active. Click the Plan View button  and select Story 4 from the Select Plan Level form.
- H. Click the **File menu** > **Save** command, or the **Save** button, , to save your model.

Step 7 Assign Wind Loads

In this Step, wind loads are assigned to the Developed Elevation View defined in Step 6. Typically, wind pressure coefficients are applied to the vertical surface of an area object. In such cases, and in this example, a positive wind pressure coefficient applies wind load in the positive local 3-axis direction of the area object. A negative wind pressure coefficient applies wind load in the negative local 3-axis direction of the area object.

- A. Click in the 3D View window to make that window active.
- B. Click the **View menu** > **Set Building View Options** command or click the **Set Building View Options** button, , to bring up the Set Building View Options form shown in Figure 37.

Figure 37
Set Building
View Op-
tions form



1. Check the Area Local Axes check box to turn on the area local axes and then click the **OK** button to exit the form. Red, white and blue arrows appear defining the area object local axes. Recall that Red = 1 axis, White = 2 axis and Blue = 3 axis.

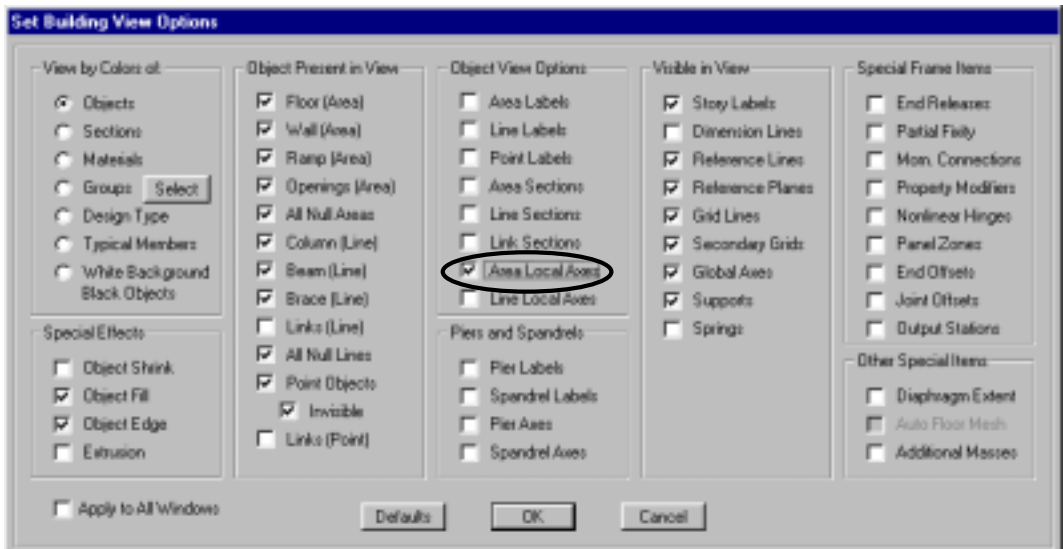

The building appears as shown in Figure 38. Notice that for the vertical dummy area objects along grid line A, the blue arrows representing the local 3-axes point to the right in the positive global X direction. Note the global axes that are located at the origin of the model.

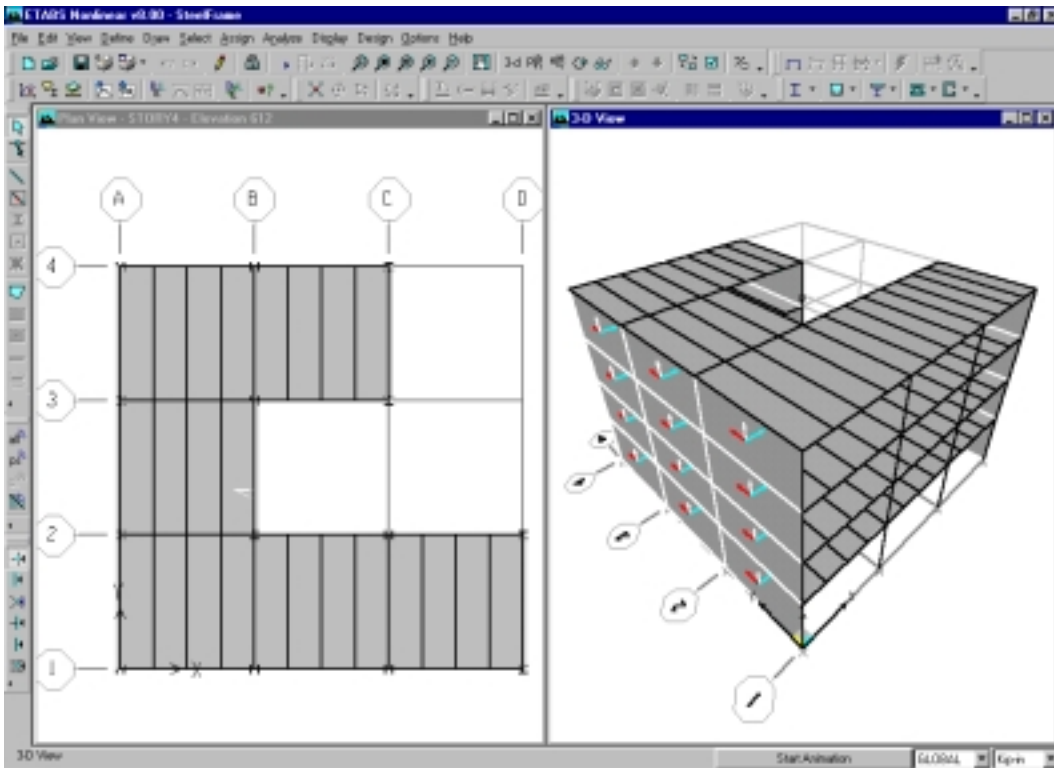
Figure 38
Area object local axes



- C. Click the **Rotate 3D View** button, , and then left click in the 3D View and hold down the left mouse button; then drag the mouse to the left. Notice that a dashed bounding box shows how the view is being rotated.

Rotate the view such that you can see the other vertical dummy area objects located on grid lines B, C and D. Confirm that the local 3 axes for those elements are also pointing in the positive global X direction.

- D. When you have confirmed that all vertical area objects have their local 3 axes pointing in the positive global X direction, click the **View menu > Set Building View Options** command or click the **Set Building View Options** button, , to bring up the Set Building View Options form. Uncheck the Area Local Axes check box to turn off the area local axes display and then click the **OK** button to exit the form.
- E. Make sure the 3D View is active and then click on the **Set Default 3D View** button, , to reset to the default 3D view.
- F. With the 3D View active, click on the **Elevation View** button, , and select A to reset the view to an elevation of grid line A.
- G. Click the left mouse button and drag the mouse to draw a "rubber band" selection box window around all of the panels in this elevation view, as shown in Figure 39.
- H. Click the **Assign menu > Shell/Area Loads > Wind Pressure Coefficient** command, which brings up the Wind Pressure Coefficient form shown in Figure 40.
 1. Select WINDX from the Wind Load Case Name drop-down box. Set the Coeff, Cp to 0.8, and check the Windward (varies) option.

Selecting the Windward option means that the wind load applied to these dummy panels will vary over the height of the building in accordance with the building code specified when the wind load was defined, in this case, ASCE 7-98.

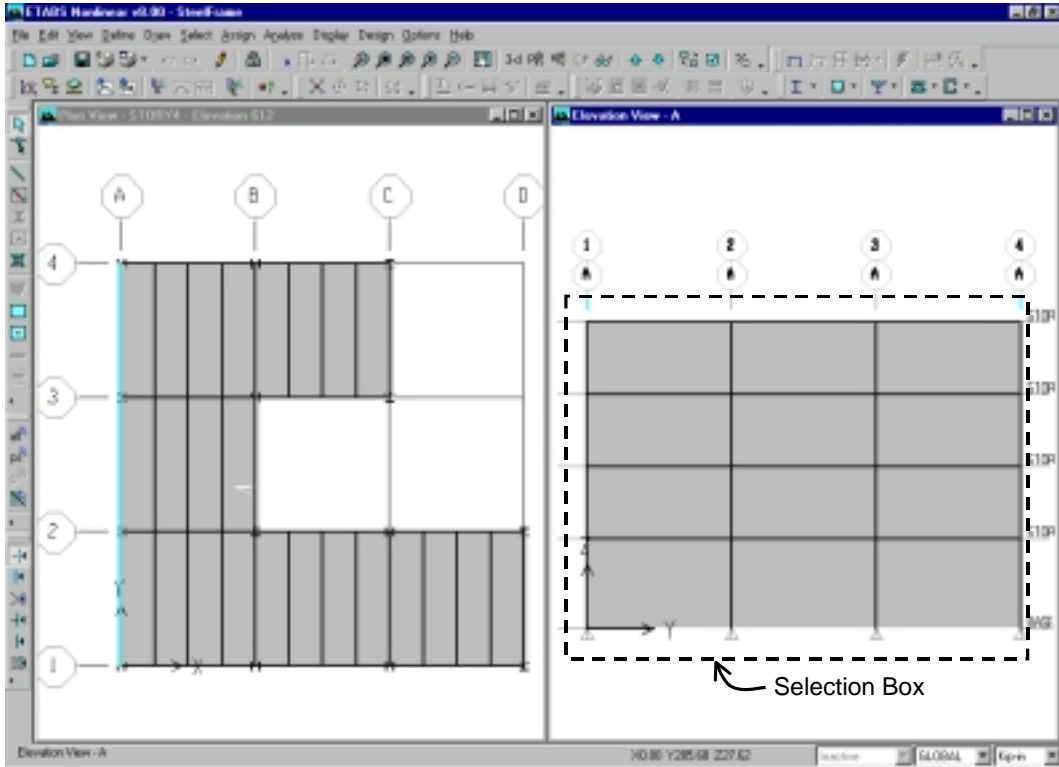

Figure 39
Selecting vertical area objects in an elevation view

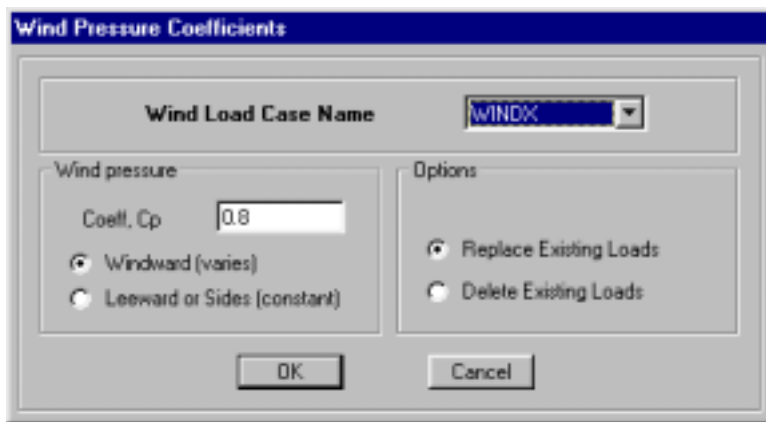

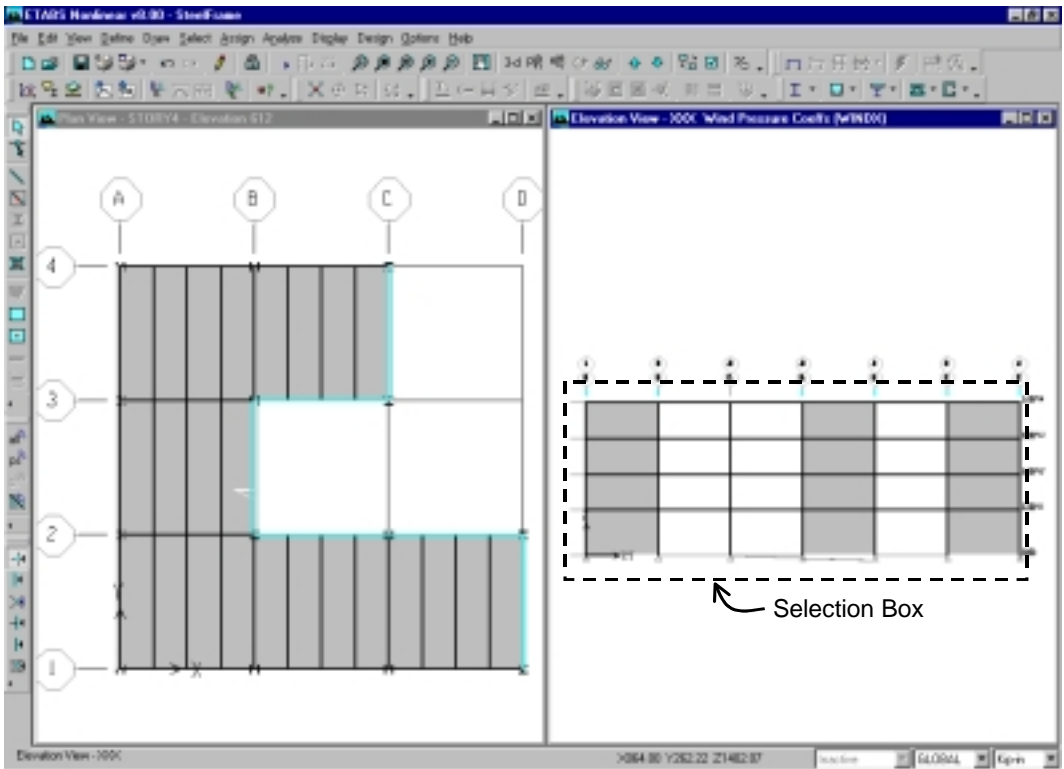

Figure 40
The Wind Pressure Coefficients form

2. Click the **OK** button to assign this load. Note that with the positive C_p , the load will act in the positive global X direction.



Figure 41
Selecting vertical area objects in a developed elevation view

- I. With the Elevation View active, click the **Elevation View** button  and select XXX to display the Developed Elevation View. Click the **OK** button. In the Developed Elevation View, click the left mouse button and drag the mouse to draw a "rubber band" selection box around all of the panels, as shown in Figure 41.



- J. Click the **Assign menu > Shell/Area Loads > Wind Pressure Coefficient** command, to bring up the Wind Pressure Coefficient form. Set the Coeff, C_p to 0.5, and check the Leeward or Sides (constant) option. Click the **OK** button to assign this load. Again, note that with the positive C_p , the load will act in the positive global X direction.

Selecting the Leeward or Sides option means that the wind load applied to these dummy panels will be constant over the height of the building in accordance with the building code specified when the wind load was defined, in this case, ASCE 7-98. The magnitude of the wind load is based on the elevation of the top of the building.

- K. Click the **Assign menu > Clear Display of Assigns** command to clear the display of the wind pressure coefficient assignments.
- L. Make sure the Elevation View is active and then click on the Set Default 3D View button, , to reset the view to the default 3D view.
- M. Click the **File menu > Save** command, or the **Save** button, , to save your model.

Step 8 Review Database Display of Input Data

In this Step, a database display of the wind pressure coefficients that were input in Step 7 will be reviewed.

- A. Click the **Display menu > Set Input Table Mode** command to bring up the Database Input Tables form. Click on the Assignments tab and then check the Wind Pressures check box as shown in Figure 42. Make sure that the Selection Only check box is *not* checked.
 - 1. Click the **OK** button to display the selected database table. The table shown in Figure 43 is displayed.

Each row in the table corresponds to one area object. Notice that the fifth column in the table, labeled C_p , displays the C_p coefficients that were input for each of the vertical area objects. The next three columns display the global X, Y and Z components of this C_p factor. In this case, all of the load is in the positive global X direction, as desired.

- 2. Click the **OK** button to close the database window.
- 3. Repeat the process to view other tables if desired.

Figure 42
The Data-
base Input
Tables form

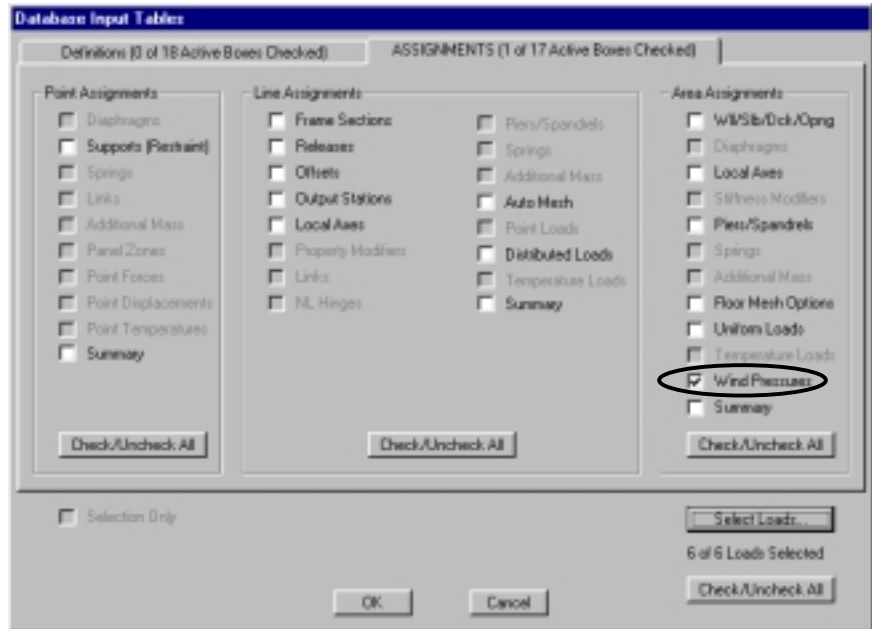

Figure 43
Database
table for
wind pres-
sure coeffi-
cients

Area Wind Pressures

Edit View

Area Wind Pressures

Case	Story	Area	Windward	Cp	XComponent	YComponent	ZComponent
WINDX	STORY4	A1	Yes	0.8000	0.8000	0.0000	0.0000
WINDX	STORY4	A2	Yes	0.8000	0.8000	0.0000	0.0000
WINDX	STORY4	A3	Yes	0.8000	0.8000	0.0000	0.0000
WINDX	STORY4	A4	No	0.5000	0.5000	0.0000	0.0000
WINDX	STORY4	A5	No	0.5000	0.5000	0.0000	0.0000
WINDX	STORY4	A6	No	0.5000	0.5000	0.0000	0.0000
WINDX	STORY3	A1	Yes	0.8000	0.8000	0.0000	0.0000
WINDX	STORY3	A2	Yes	0.8000	0.8000	0.0000	0.0000
WINDX	STORY3	A3	Yes	0.8000	0.8000	0.0000	0.0000
WINDX	STORY3	A4	No	0.5000	0.5000	0.0000	0.0000
WINDX	STORY3	A5	No	0.5000	0.5000	0.0000	0.0000
WINDX	STORY3	A6	No	0.5000	0.5000	0.0000	0.0000
WINDX	STORY2	A1	Yes	0.8000	0.8000	0.0000	0.0000
WINDX	STORY2	A2	Yes	0.8000	0.8000	0.0000	0.0000
WINDX	STORY2	A3	Yes	0.8000	0.8000	0.0000	0.0000
WINDX	STORY2	A4	No	0.5000	0.5000	0.0000	0.0000
WINDX	STORY2	A5	No	0.5000	0.5000	0.0000	0.0000
WINDX	STORY2	A6	No	0.5000	0.5000	0.0000	0.0000
WINDX	STORY1	A1	Yes	0.8000	0.8000	0.0000	0.0000
WINDX	STORY1	A2	Yes	0.8000	0.8000	0.0000	0.0000
WINDX	STORY1	A3	Yes	0.8000	0.8000	0.0000	0.0000
WINDX	STORY1	A4	No	0.5000	0.5000	0.0000	0.0000
WINDX	STORY1	A5	No	0.5000	0.5000	0.0000	0.0000
WINDX	STORY1	A6	No	0.5000	0.5000	0.0000	0.0000

Navigation buttons: Home, Left, Right, End, OK

Step 9 Run the Analysis

In this Step, the analysis will be run.



Note:

*The ETABS
Software
Verification
Manual
documents
analysis
using ETABS.*



- A. Click the **Analyze menu > Run Analysis** command or the Run Analysis button, , and click the **Run** button on the Run Options form.

The program will create the analysis model from your object-based ETABS model, and will soon display an "Analyzing, Please Wait" window. Data will scroll in this window as the program runs the analysis. After the analysis has been completed, the program performs a few more bookkeeping actions that are evident on the status bar in the bottom left-hand corner of the ETABS window.

When the entire analysis process has been completed, the model automatically displays a deformed shape view of the model, and the model is locked. The model is locked when the Lock/Unlock Model button, , appears depressed. Locking the model prevents any changes to the model that would invalidate the analysis results.

Step 10 Graphically Review the Analysis Results

In this Step, the analysis results will be reviewed using graphical representation of the results.

- A. Make sure the 3D View is active. Then click on the **Elevation View** button, , and select 1 and click the **OK** button to reset the view to an Elevation View of grid line 1.
- B. Click the **Show Frame/Pier/Spandrel Forces** button, , or the **Display menu > Show Member Force/Stresses Diagram > Frame/Pier/Spandrel Forces** command to bring up the Member Force Diagram for Frames form shown in Figure 44.

1. Select DEAD Static Load from the Load drop-down box.
2. Select the Moment 3-3 option.
3. Uncheck the Fill Diagram if it is checked.
4. Check the Show Values on diagram check box.
5. Click the **OK** button to generate the moment diagram output shown in Figure 45.



Figure 45
M33 moment diagram in an elevation view

Figure 44
Member Force Diagram for Frames form

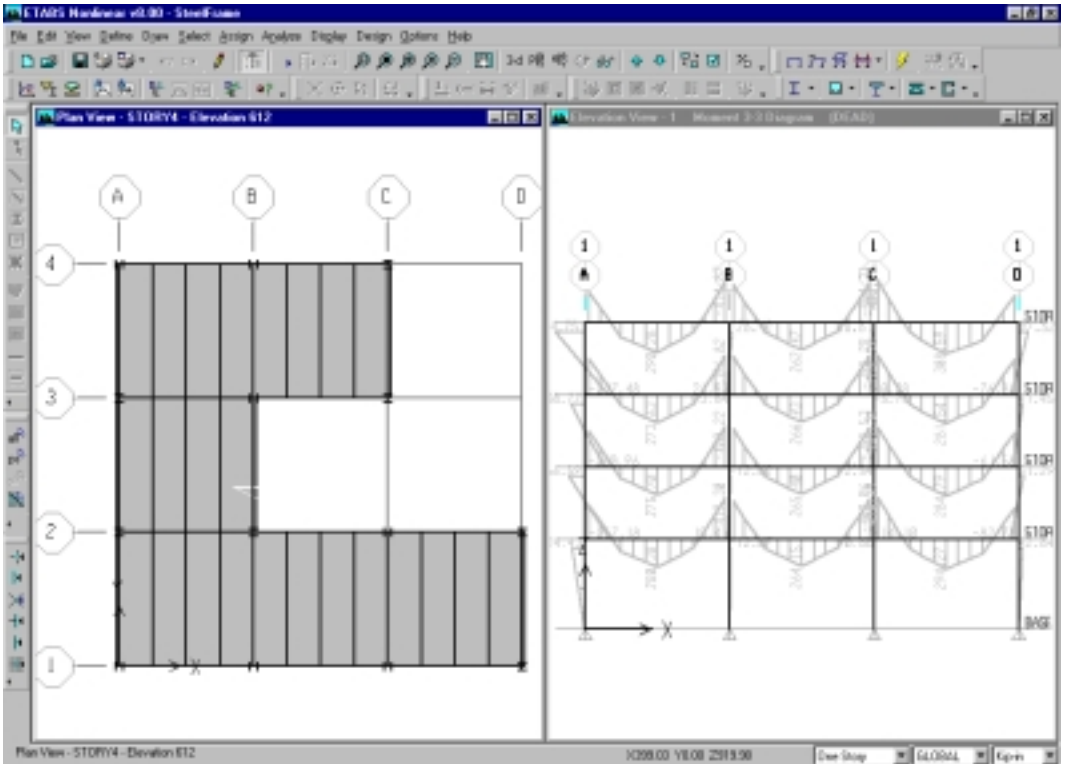

Note that these moment diagrams are plotted with the positive moment on the tension side of the member. Change this, if desired, using the **Options menu > Moment Diagrams on Tension Side** command toggle.

- C. Right click on the top level beam between grid lines A and B to bring up the Diagram for Beam form shown in Figure 46.

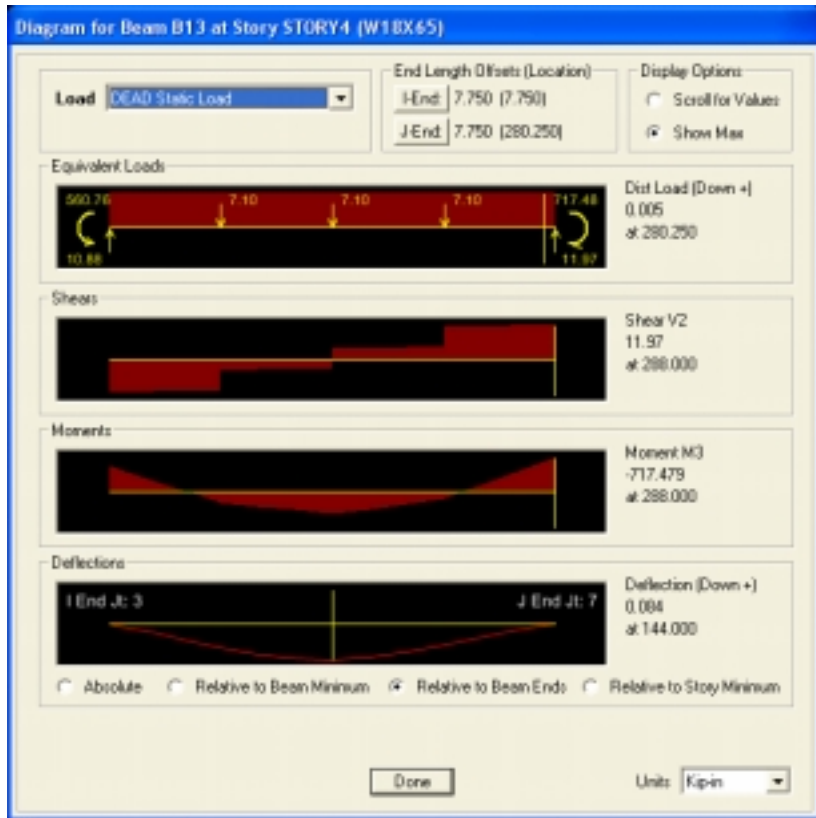



Figure 46
Force details obtained by right-clicking a beam shown in the elevation view in Figure 45

Note that the applied load, shear, moment and deflection are shown for the beam, and the maximum values are identified on the Diagram for Beam form. The Uniform Load shown for the beam is the tributary load from the deck plus the self weight of the beam. Tributary concentrated loads are not shown.

1. Click the Scroll for Values option and a scroll bar appears at the bottom of the form. Drag the scroll bar with your mouse to see values at different locations along the beam.
 2. Set the Units drop-down box at the bottom of the form to kip-ft. Then type 6.5 into the Location edit box. The load, shear, moment and deflection values are displayed at this exact location in kip and feet units.
 3. Click the Load drop-down box and select CLADDING Static Load from the list to display the forces acting on this beam from the superimposed dead load named CLADDING. The Dist (Distributed) Load (Down+) should display a value of 0.250 klf, which is the cladding load that was applied in Step 5.
 4. Click the **Done** button to close the form.
- D. Make sure the Elevation View is active and then click the **Display menu > Show Undeformed Shape** command or the **Show Undeformed Shape** button, , to clear the display of the moment diagrams in the Elevation View.
- E. Make sure the Elevation View is active and then click on the **Set Default 3D View** button, , to reset the view to the default 3D view.

Step 11 Design the Composite Beams

In this Step, the composite beams will be designed. Note that the analysis (Step 9) should be run before completing the following Action Items.

- A. In the Plan View, right click on one of the secondary (infill) beams in the bay bounded by grid lines 1, 2, A and B. The Line Information form shown in Figure 47 appears.

Line Information

Location | Assignments | Loads

Identification

Label: B28 Line Type: Beam

Story: STORY4 Design Procedure: Composite Beam

Length	288.
Start Point (I)	28
Story	STORY4
X	144.
Y	0.
Delta Z	0.
End Point (J)	17
Story	STORY4
X	144.
Y	288.
Delta Z	0.

Units: Kip-in

OK

Figure 47
Line Information form



Note:
To change the design procedure for a beam, select the beam and use the **Design menu > Overwrite Frame Design Procedure** command.

Note that the form reports that the Design Procedure for this form is Composite Beam. The program assigned this default design procedure to this line object because (1) it lies in a horizontal plane, (2) the ends of the beam are pinned (that is, moment is released at each end of the beam), and (3) it is assigned a steel section that is either I-shaped or a channel.

Review the information available on all three tabs of the Line Information form and then click the **OK** button to close the form.

- B. Click the **Options menu > Preferences > Composite Beam Design** command. The Preferences form shown in Figure 48 appears.

Figure 48
Preferences
form for
composite
beam design

Preferences	
Factors	
Beam	Deflection
Vibration	Price
Shored?	No
Middle Range (%)	70
Pattern Live Load Factor	0.75
Stress Ratio Limit	0.95
Single Segment?	No
Reset Tab	
Design Code	AISC-LRFD93
Reset All	OK
Cancel	

1. Click the Design Code drop-down box near the bottom of the form to see the available design codes. Select the AISC-LRFD93 code.
 2. Review the information available on all five tabs in the Preferences form and then click the **OK** button to accept the Design Code change.
- C. Click on the title bar of the 3D View to activate 3D view.
- D. Click the **Set Building View Options** button . When the Set Building View Options form appears, uncheck the Object Fill check box as shown in Figure 49. This will remove the display of the fill in the area objects.

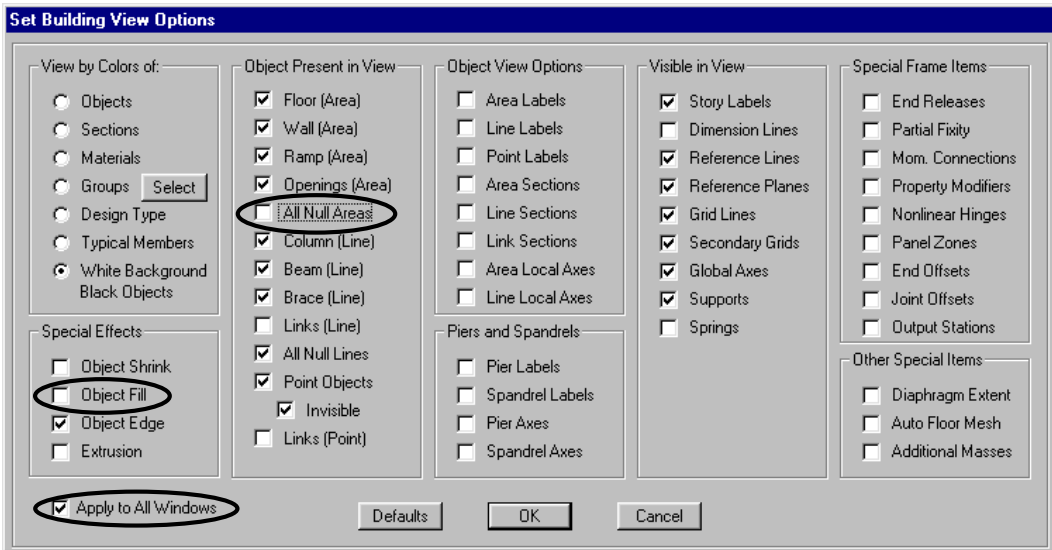

Figure 49
Set Building
View Op-
tions form

1. In the Object Present in View area of the form, uncheck the All Null Areas check box.
2. Check the Apply to All Windows check box and click the **OK** button to accept the changes.



Note:
The Start Design Without Similarity command is only available after the analysis has been run.

- E. With the 3D View active, click the **Design menu > Composite Beam Design > Start Design Without Similarity** command to start the design process. The program designs the composite beams, selecting the optimum beam size from the A-CompBm auto select section list that was assigned to them when they were drawn in Step 2.

When the design is complete, the selected sizes are displayed on the model. The model appears as shown in Figure 50.

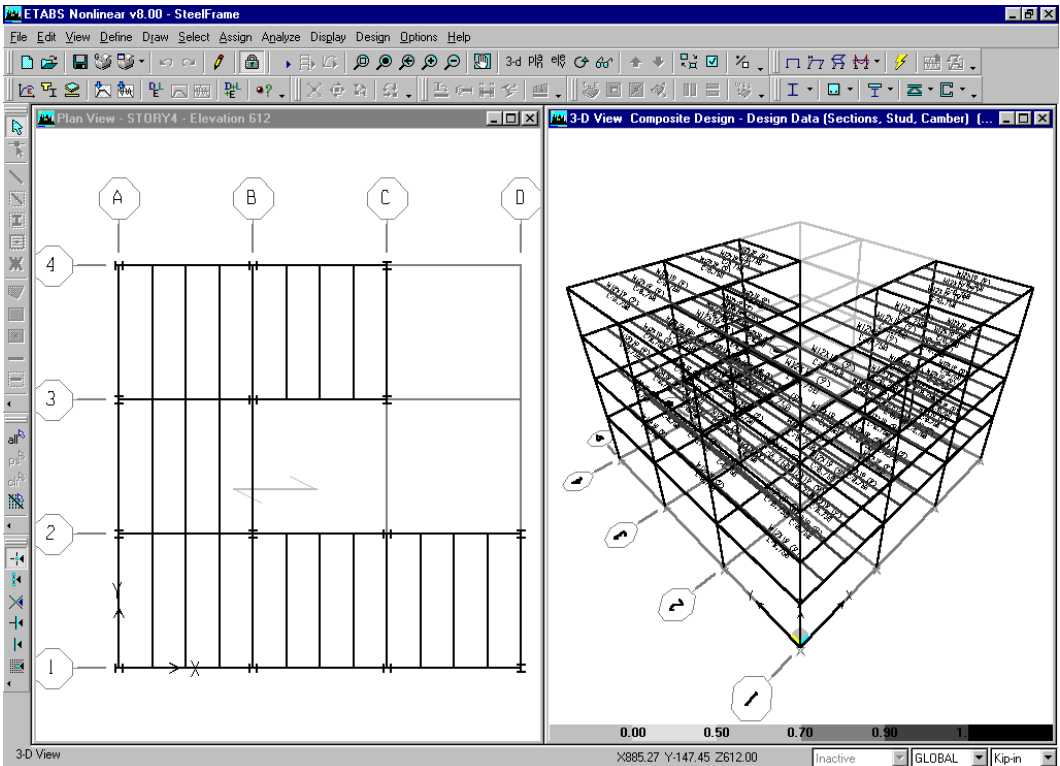
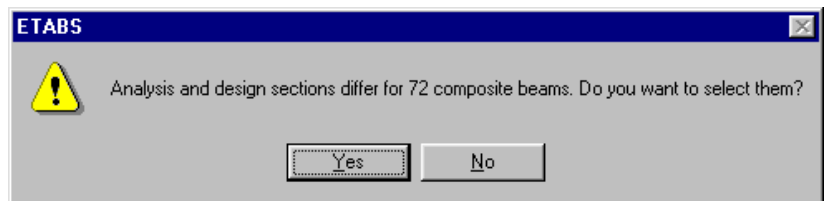

Figure 50
Model after the initial composite design

- F. Click the **Design** menu > **Composite Beam Design** > **Verify Analysis vs Design Section** command. A message similar to the one shown in Figure 51 appears. Click the **No** button to close the form.

Figure 51
Analysis vs Design Section warning message for an incomplete design



In the initial analysis (Step 9), the program used the median section by weight from the A-CompBm auto select section list. During design (this Step), the program selected a W12X19 design section, which differs from the analysis section used. The message in Figure 51 indicates that the analysis and design sections are different.

The goal is to repeat the analysis (Step 9) and design (Step 11) process until the analysis and design sections are all the same. Note that when the building is reanalyzed (i.e., Step 9 is repeated), ETABS will use the current design sections (i.e., those selected in Step 11) as new analysis sections for the next analysis run. Thus, in the next analysis of this example, the composite beams will be analyzed using W12X19 analysis sections.

- G. Right click on one of the composite beams in the 3D View shown in Figure 50. The Interactive Composite Design and Review form shown in Figure 52 appears.

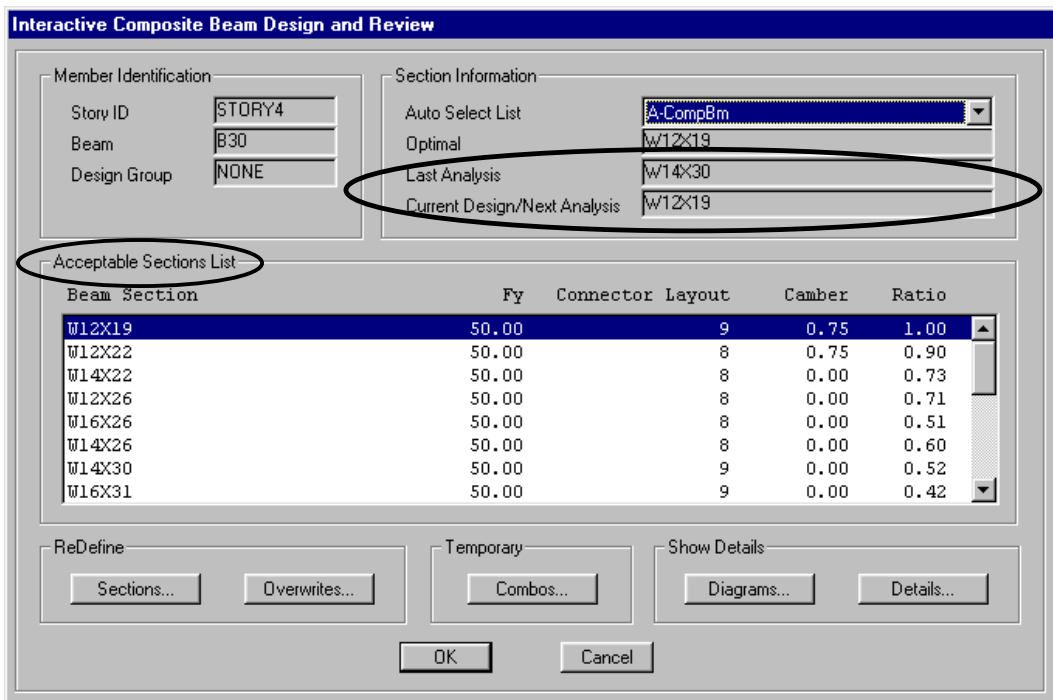

Figure 52
Interactive Composite Beam Design and Review form

Note that the current design section is reported as W12X19 and the last analysis section is reported as W14X30.

The Acceptable Sections List shows all of the beams in the A-CompBm auto select section list that are adequate for the design forces.

1. Click on the **Details** button in the Interactive Composite Beam Design and Review form. The Composite Beam Design Form shown in Figure 53 appears. This form shows detailed design information about the beam. Review the information on each of the four tabs in this form. Then click the X in the upper right-hand corner of the form to close it.

Figure 53
Composite
Beam
Design form

Composite Beam Design (AISC-LRFD93)			
Summary	Strength	Stud Details	Serviceability
AISC-LRFD93	Composite Beam Design	Beam Label: B30	Units: Kip-in
Beam Label: B30	Story: STORY4	Shored: No	Overwrites: No
Group: None	Length: 288.000	Camber: 0.750	b-cp: N/A
Beam: W12x16	Loc X: 72.000	Comparative: \$0.38	t-cp: N/A
Fy: 50.000	Loc Y: 720.000	Stud Diam.: 0.750	Fy-cp: N/A
Fu: 65.000	RLLF: 1.000		Consider-cp: No
Deck Left: DECK1	Deck Right: DECK1	bEFF Left: 36.000	bEFF Right: 36.000
Dir. Left: Perpdclr	Dir. Right: Perpdclr	F'c Left: 4.000	F'c Right: 4.000
Ctop Left: 1.000	Ctop Right: 1.000	Ec(S) Left: 3834.254	Ec(S) Right: 3834.254
Cbot Left: 0.000	Cbot Right: 0.000	Ec(D) Left: 3600.000	Ec(D) Right: 3600.000
		Ec(V) Left: 5176.242	Ec(V) Right: 5176.242
Is: 103.00	ybare: 6.000	leff(S): 416.47	yeff(S): 13.378
Ibare: 103.00	ytrans(S): 15.013	leff(D): 412.86	yeff(D): 13.306
Itrans(S): 570.18	ytrans(D): 14.931	leff(V): 594.66	yeff(V): 15.357
Itrans(D): 564.80			
Itrans(V): 594.66			
Qn: 26.51			
Stud Layout: 8			
Seg. Length: 279.410			
Stud Ratio: 0.348			
PCC: 45.02%	Utilization Limit: 0.950		
Overall Ratio: 0.948	Stress Ratio: 0.850	Deflection Ratio: 0.948	

2. Click the **Cancel** button to close the Interactive Composite Design and Review form.

- H. To rerun the analysis with the new analysis sections for the composite beams, click the **Analyze menu > Run Analysis** command or the **Run Analysis** button, , and click the **Run** button on the Run Options form.
- I. When the analysis is complete, click the **Design menu > Composite Beam Design > Start Design Without Similarity** command to start the composite beam design process.
- J. Click the **Design menu > Composite Beam Design > Verify Analysis vs Design Section** command. The message shown in Figure 54 should appear, indicating that the analysis and design sections are the same for all composite beams. Click the **OK** button.



Note:

Use the **File menu > Print Tables > Composite Beam Design** command to print summary and detailed composite beam design information.

Figure 54
Analysis vs
Design Section
warning
message for
a complete
design





If you do not get this message, repeat Action Items H, I and J until you do get it, before proceeding to the next Action Item.

- K. Click the **Design menu > Composite Beam Design > Verify All Members Passed** command. The message shown in Figure 55 should appear, indicating that all composite beams passed the design check. Click the **OK** button to close the form.

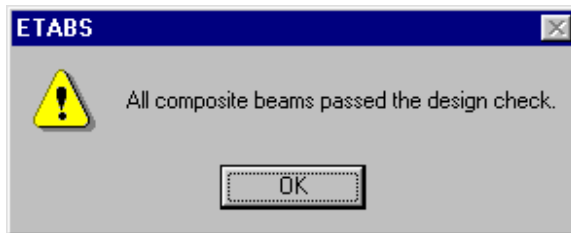
Figure 55
Verify All
Members
Passed
warning
message for
a complete
design



- L. Click the **Select All** button, , or click the **Select menu > All** command, or press the Ctrl and A keys simultaneously on your keyboard to select all objects in the model.
- M. Click the **Design > Composite Beam Design > Make Auto Select Section Null** command and click the **OK** button for the resulting message. This removes the auto select section list assignments from the composite beam members and replaces them with their current design sections.
- N. Click the **Assign menu > Clear Display of Assigns** command. Also click the **Clear Section** button, , to clear the selection.
- O. Click the **File menu > Save** command, or the **Save** button, , to save your model. The composite beam design is now complete.

Step 12 Design the Steel Frame

In this Step, steel frame design is completed. Note that the analysis (Step 9) should be run before performing the following Action Items.

- A. Click the **Options menu > Preferences > Steel Frame Design** command. Select AISC-ASD01 from the Design Code drop-down list.
- B. In the Plan View, right click on the beam along grid line A between grid lines 1 and 2. The Line Information form shown in Figure 56 appears. Review the information. Note that the design procedure for this beam is Steel Frame. Click the **OK** button to close the form.
- B. Click on the title bar of the 3D View to activate 3D view. This allows the design results to appear in the 3D View.
- C. Click the **Design > Steel Frame Design > Start Design/Check of Structure** command or click the **Start Steel Design/Check of Structure** button, , to start the steel frame design process. The columns and the lateral beams that span between columns are designed.
- D. When the initial design is complete, a form similar to that shown in Figure 57 appears.

Similar to composite design (described in Step 11), in the initial analysis, the program used the median section by weight from the AUTOLATBM and A-LatCol auto select section lists for the analysis. The design sections chosen differ from the analysis sections used. The message in Figure 57 indicates that the analysis and design sections are different.

1. Click the **No** button to close the form.

Line Information

Location | Assignments | Loads

Identification

Label: B4 Line Type: Beam

Story: STORY4 Design Procedure: Steel Frame

Length	288.
Start Point (I)	C4
Story	STORY4
X	0.
Y	0.
Delta Z	0.
End Point (J)	C5
Story	STORY4
X	0.
Y	288.
Delta Z	0.

Units: Kip-in

OK

Figure 56
Line Information form

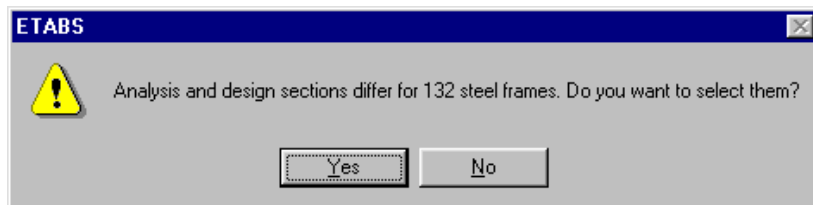

Figure 57
Analysis vs Design Section warning message for an incomplete design

- E. Click on the title bar of the Plan View to activate the view.
- F. Click the **Design > Steel Frame Design > Display Design Info** command. The Display Design Results form appears.
 1. Make sure that the Design Output option is selected and that P-M Ratio Colors & Values is selected in the Design Output drop-down box. Then click the **OK** button.

Results are displayed in the Plan View and the model appears as shown in Figure 58.

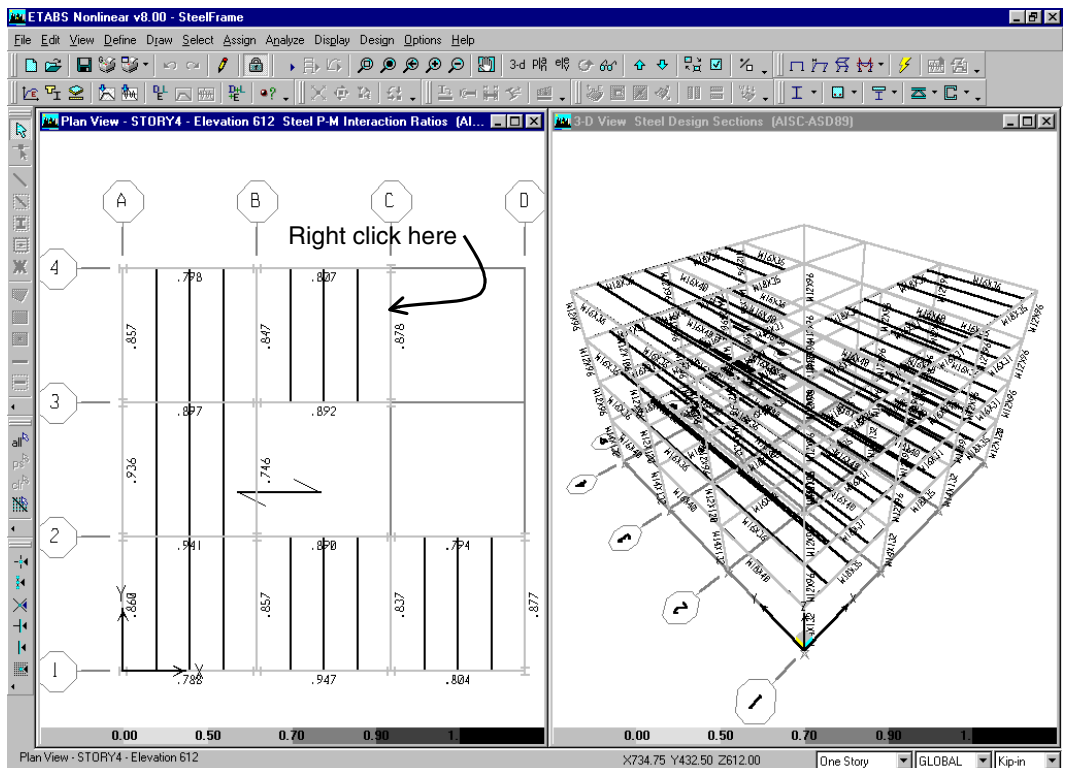

Figure 58
Model after
the initial
steel frame
design

- G. In the Plan View, right click on the beam along grid line C between grid lines 3 and 4 as indicated in Figure 58. The Steel Stress Check Information form shown in Figure 59 appears. Note that the reported analysis and design sections are different.

Steel Stress Check Information (AISC-ASD01)

Story: Analysis Section:
 Beam: Design Section:

COMBO ID	STATION LOC	/---MOMENT RATIO	INTERACTION CHECK =	AXL + B-MAJ + B-MIN	//-MAJ-SHR---MIN-SHR-/ RATIO	RATIO
DSTL2	53.17	0.279 (C)	=	0.068 + 0.209 + 0.002	0.073	0.000
DSTL2	75.88	0.543 (C)	=	0.068 + 0.473 + 0.002	0.055	0.000
DSTL2	98.58	0.733 (C)	=	0.068 + 0.663 + 0.002	0.037	0.000
DSTL2	121.29	0.847 (C)	=	0.068 + 0.777 + 0.002	0.019	0.000
DSTL2	144.00	0.886 (C)	=	0.068 + 0.816 + 0.002	0.000	0.000

Overwrites Details

OK Cancel

Figure 59
Steel Stress Check Information form

The main body of the form lists the design stress ratios obtained at various stations along the beam for each design load combination. Note that the program automatically created code-specific design load combinations for this steel frame design. (It also did this for the composite design.)

Note:

Use the **File menu > Print Tables > Steel Frame Design** command to print additional steel frame design information.

Click the **Details** button on the Steel Stress Check Information form. The Steel Stress Check Information AISC-ASD89 form shown in Figure 60 appears. Note that you can print this information using the File menu on the form.

Click the X in the upper right-hand corner of the Steel Stress Check Information AISC-ASD89 form to close it.

Click the **Cancel** button to close the Steel Stress Check Information form.

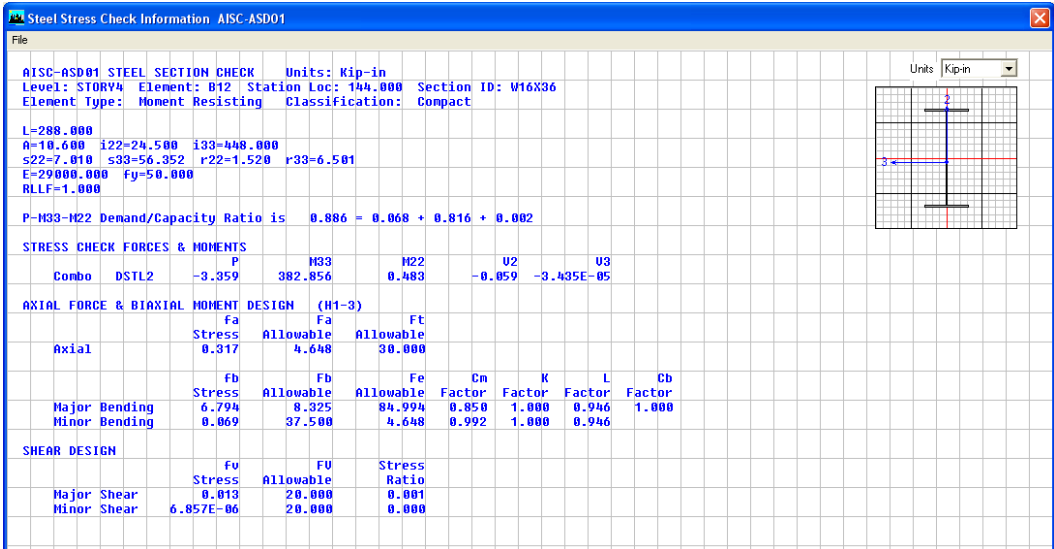

Figure 60
Steel Stress
Check In-
formation
AISC-
ASD89 form

H Click the **Design > Steel Frame Design > Select Design Combo** command. The Design Load Combinations Selection form shown in Figure 61 appears.

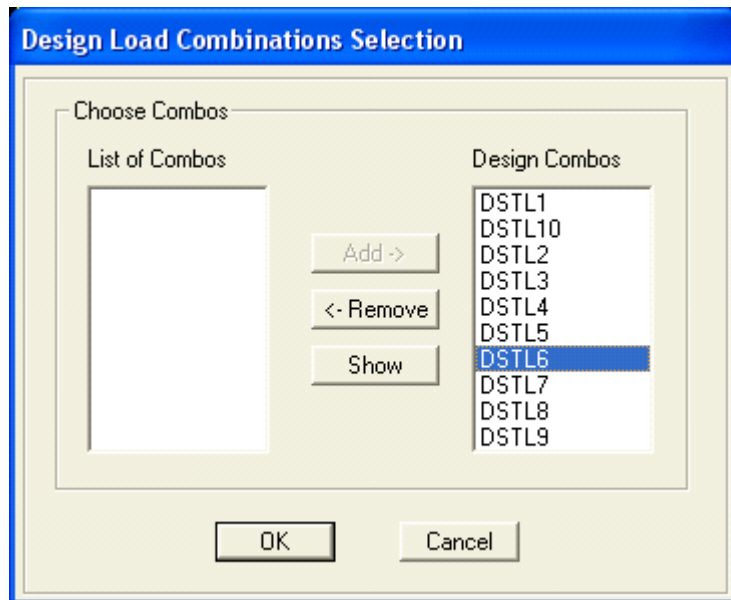





Figure 61
Design Load
Combination
Selection
form

The Design Combos list identifies the ten default steel frame design load combinations created by the program. Click on DSTL6 to highlight it and then click the **Show** button. The Load Combination Data form shown in Figure 62 pops up, showing how the program defined design load combination DSTL6.

Figure 62
Load Combination
Data form

Case Name	Scale Factor
CLADDING Static Load	1
DEAD Static Load	1
SDEAD Static Load	1
WINDX Static Load	-1

1. Click the **OK** button in the Load Combination Data form to close it. If desired, review other design load combination definitions and then click the **OK** button to close the Data form.
2. Click the **Cancel** button in the Design Load Combinations Selection form to close it without accepting any changes that may have inadvertently been made.
 - I. Click on the title bar of the Plan View to activate the view.
 - J. Click the **Display menu > Show Undeformed Shape** command or the **Show Undeformed Shape** button, , to clear the display of the stress ratios.

- K. Click on the title bar of the 3D View to activate the 3D view.
- L. To rerun the analysis with the new analysis sections for the steel beams, click the **Analyze menu > Run Analysis** command or the **Run Analysis** button, , and click the **Run** button on the Run Options form.
- M. When the analysis is complete, a deformed shape will display. Click the **Design > Steel Frame Design > Start Design/Check of Structure** command or click the **Start Steel Design/Check of Structure** button, , to start the steel frame design process.

When the design is complete, a message will pop up indicating how many design sections are different from the analysis sections. Click the **No** button to clear the pop up box.

Repeat Action Items L and M until the analysis and design sections are the same, which is indicated when no message pops up at the end of the design (and the "wait hour glass" has disappeared). This may take five or more iterations for this example.



- N. When the analysis and design sections are the same, click the **Select All** button, , or click the **Select menu > All** command, or press the Ctrl and A keys simultaneously on your keyboard to select all objects in the model.
- O. Click the **Design > Steel Frame Design > Make Auto Select Section Null** command and click **OK** for the resulting message. This removes the auto select section list assignments from the steel frame members and replaces them with their current design sections.
- P. Click the **Design > Steel Frame Design > Verify All Members Passed** command. A form similar to that shown in Figure 63 should appear indicating that all members passed.

Figure 63
Verify All
Members
Passed
warning
message for
a complete
design



Note that members not passing at this stage is an indication of inadequate sections in the auto select list. The program would have used the largest section in the auto select list for both analysis and design, finding it inadequate. In that case, either add more sections to the auto select list or assign a larger sections to the members that did not pass and continue with the design process.

- Q. Click the **Clear Section** button, , to clear the selection. Click the **File menu > Save** command, or the **Save** button, , to save your model. The steel frame design and this introduction to ETABS Version 8 are now complete.